

BMC



BMC

Create Speed.

ICS Carbon Aero Cockpit



**Speed changes
the game.
Your equipment needs
to evolve.**



Introducing the next generation of cockpit design. Don't just think aero only. Ergonomics and stiffness are the new performance drivers. BMC sets a new benchmark with a cockpit - engineered for racing.



ERGONOMICS

Wider aero tops

Improved transition to levers

New 12° flare design

Updated drop curvature

Better Lever Fit

Less "hooking"



SRAM D1

SRAM E1

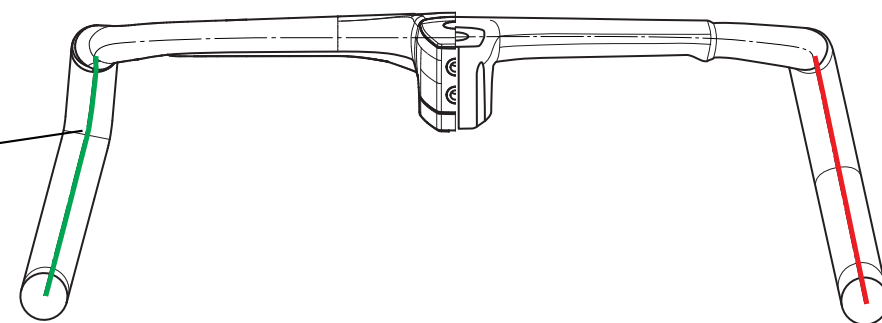

Aero Gen 1

Aero Gen 2

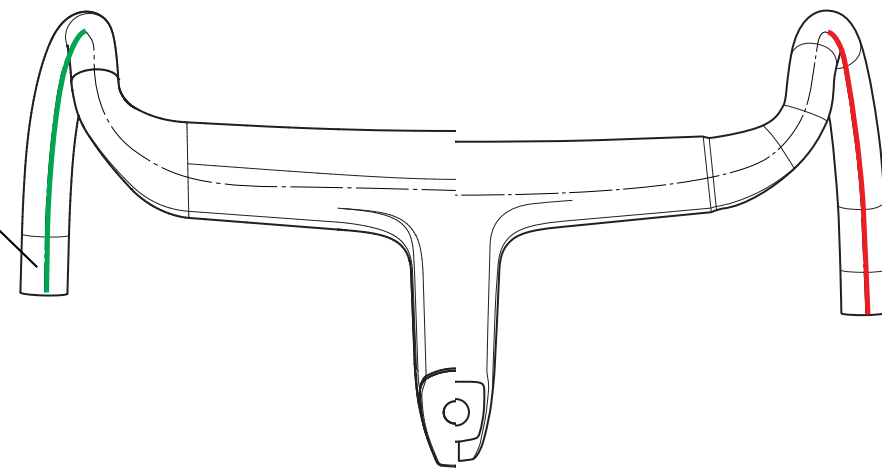

Ergonomics – Improved

Designed with a compact width of 370mm (hoods) and 420mm (drops). It replicates exactly the contact points of the previous generation.

A 12° flare, ensure optimal ergonomics and positioning. The drops are designed inline with today's offset brake levers (SRAM Red). BMC's progressive drop shape ensures confident handling and smooth hand transitions from the different grip positions on the bar.

Multiple stem lengths are available: from 90 to 120mm in 10mm increments —to dial in your race fit. External cable routing is streamlined and simple, with clean under-bar covers. Delivered with a computer mount compatible with Garmin and Wahoo devices, plus a GoPro interface that will let you bolt additional accessories of your choice (light, camera, etc.).

Ergonomics – Contact Points

Your speed depends on how efficiently your position allows your body to generate power. Hand placement plays a crucial role in upper-body positioning and directly influences your aerodynamic performance on the bike.

The hand positions on the hoods and in the drops remain unchanged from the previous generation of the BMC Aero cockpit.

The hoods are spaced 370 mm apart, ensuring the handlebar complies with the latest UCI regulations.

The drop shape has been slightly refined to meet the demands of the world's fastest riders. It locks your hands securely when descending or sprinting—offering not only comfort, but also the confidence to maintain maximum speed with full control.

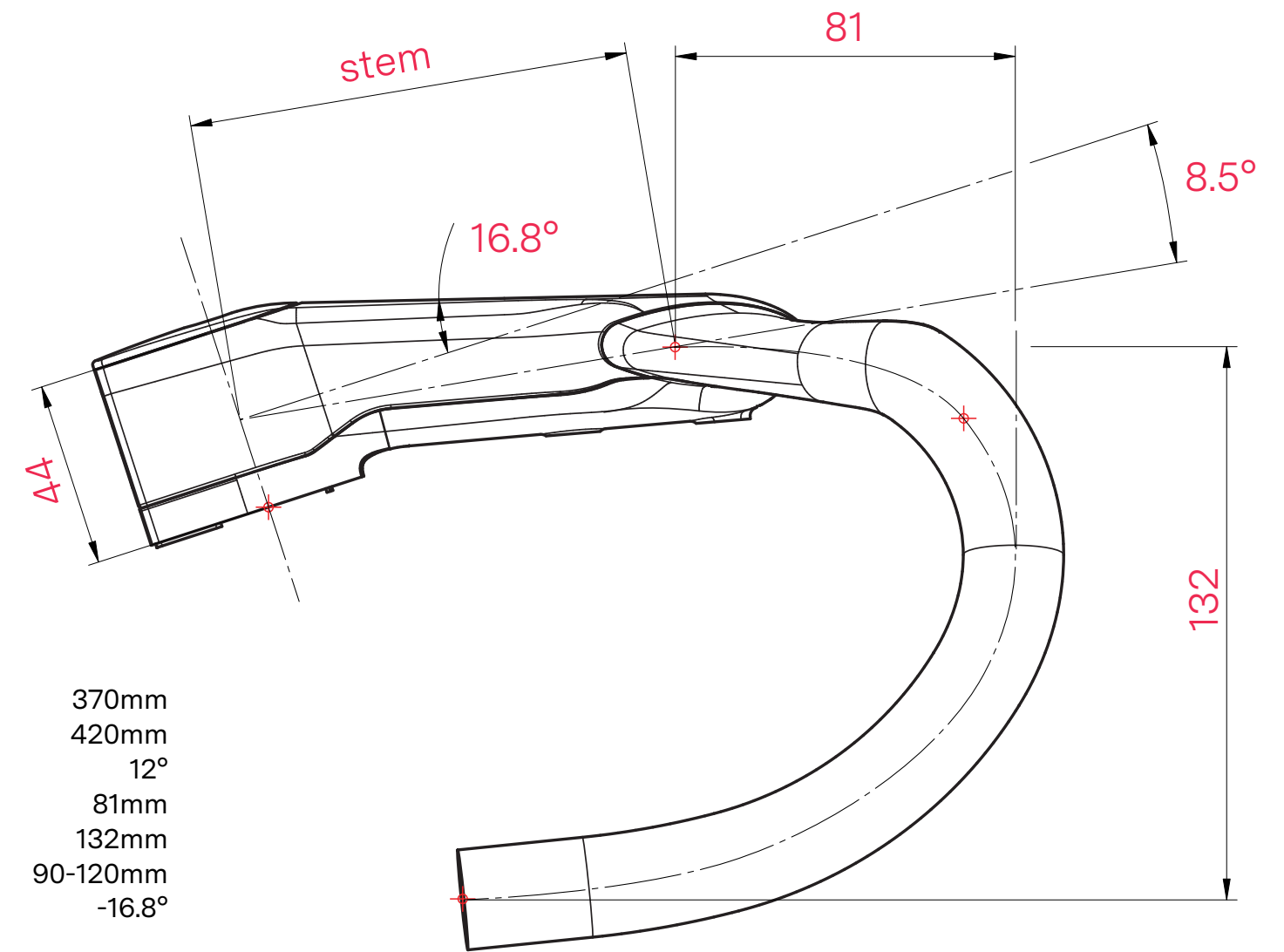

Aero Gen1 vs Gen2

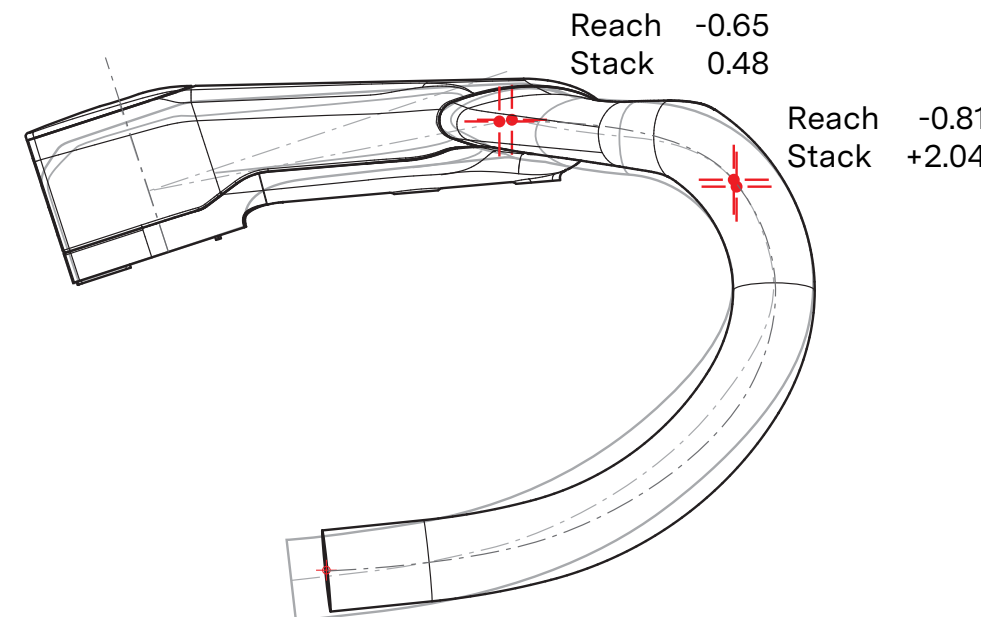

Evo vs Aero Gen2

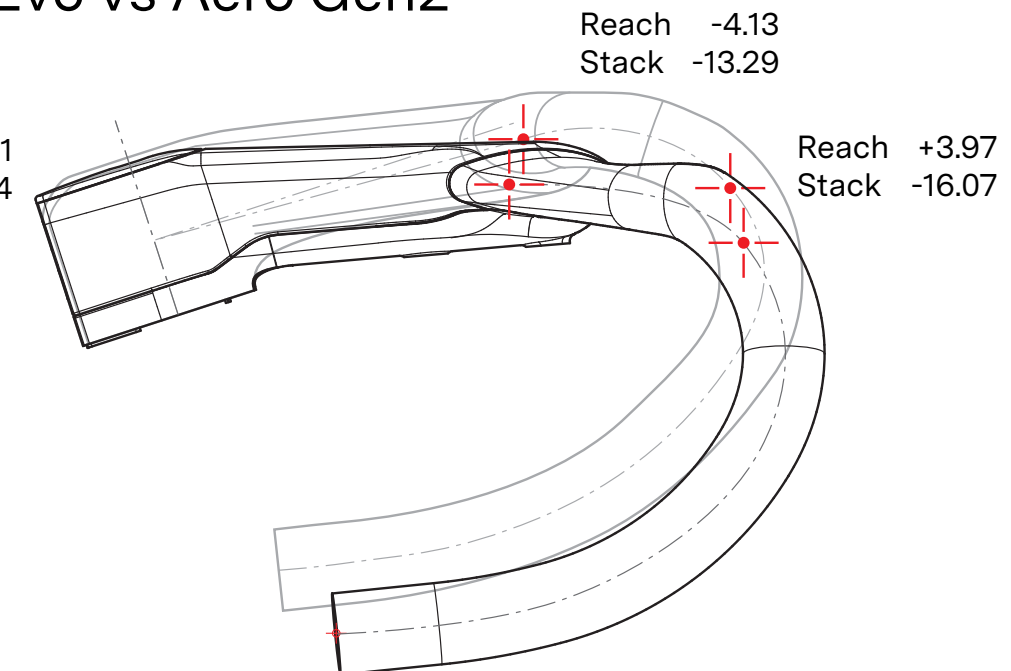

Ergonomics – Brake Lever Fit

Optimized for the latest generations of brake levers for better ergonomics.

More control,
More comfort,
Faster.

SHIMANO, SRAM and CAMPAGNOLO brake lever contact surfaces with the handlebar have been studied to provide wider range of adjustment and better mechanical connection ensuring a strong and stable lever assembly.



Ergonomics – UCI Rules 2026

From January 1st of 2026, the UCI introduced new equipment regulations—including handlebar widths, rim depth, fork dimensions, helmet requirements, and even a gear ratio trial—focused on rider safety in UCI-sanctioned racing.

These changes apply to professional competition but do not directly affect the broader commercial lineup.

All our framesets, cockpits, handlebars, seatposts and wheels comply with these new rules. This includes our ICS Carbon Aero Gen 1 and Gen 2 cockpits.

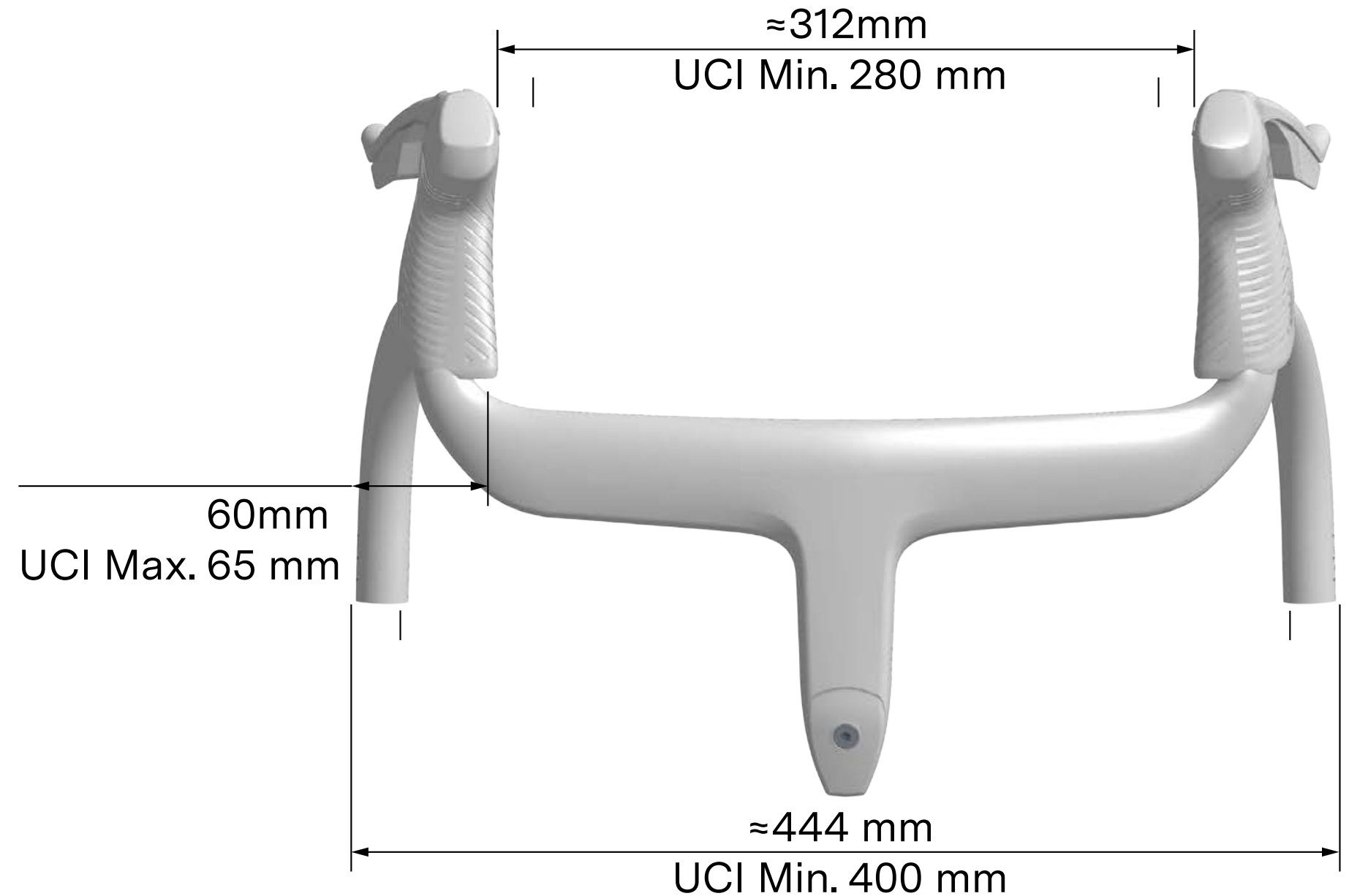

Handlebar Width

A - Minimum width of 400 mm (between the two outer edges).

B - Minimum width of 280 mm (between the inner edges of the brake levers).

Maximum 65 mm between the inside of the brake lever and the outer edge of the handlebar.



Ergonomics - Geometry

ICS Carbon Aero Cockpit Mpc.

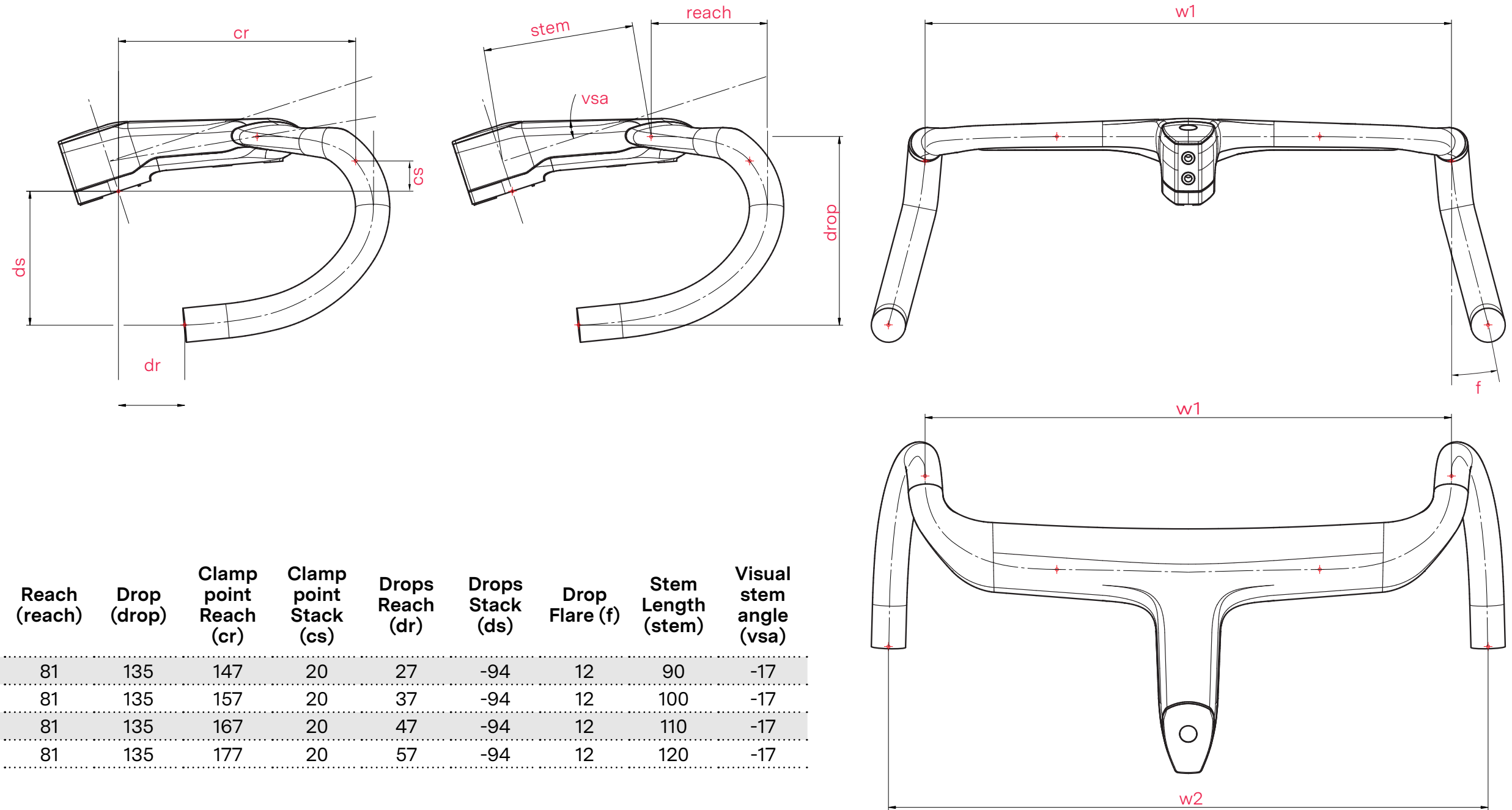

SKU	Variation	Width at hoods (w1)	Width at Drops (w2)	Reach (reach)	Drop (drop)	Clamp point Reach (cr)	Clamp point Stack (cs)	Drops Reach (dr)	Drops Stack (ds)	Drop Flare (f)	Stem Length (stem)	Visual stem angle (vsa)
30007862	Mpc. 90-370/420	370	420	81	135	147	20	27	-94	12	90	-17
30007863	Mpc. 100-370/420	370	420	81	135	157	20	37	-94	12	100	-17
30007864	Mpc. 110-370/420	370	420	81	135	167	20	47	-94	12	110	-17
30007865	Mpc. 120-370/420	370	420	81	135	177	20	57	-94	12	120	-17

Ergonomics - Geometry

ICS Carbon Aero Cockpit Gen2

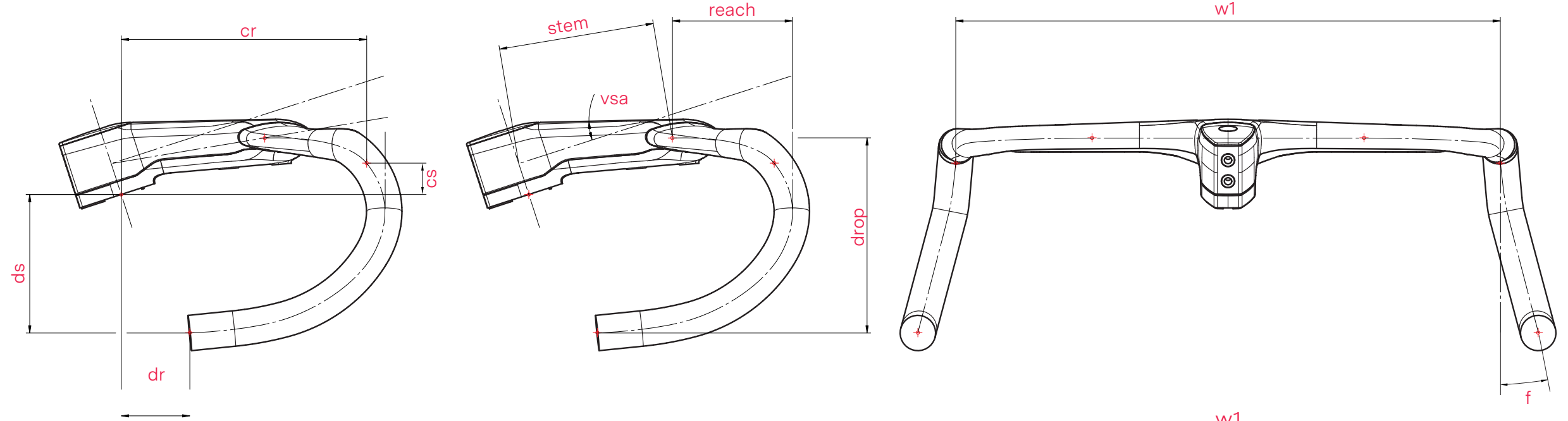

SKU	Variation	Width at hoods (w1)	Width at Drops (w2)	Reach (reach)	Drop (drop)	Clamp point Reach (cr)	Clamp point Stack (cs)	Drops Reach (dr)	Drops Stack (ds)	Drop Flare (f)	Stem Length (stem)	Visual stem angle (vsa)
30007867	80-370/420	370	420	81	135	137	20	17	-94	12	80	-17
30007868	90-370/420	370	420	81	135	147	20	27	-94	12	90	-17
30007869	100-370/420	370	420	81	135	157	20	37	-94	12	100	-17
30007870	110-370/420	370	420	81	135	167	20	47	-94	12	110	-17
30007871	120-370/420	370	420	81	135	177	20	57	-94	12	120	-17
30007872	130-370/420	370	420	91	135	187	20	67	-94	12	120	-17
30007873	140-370/420	370	420	91	135	197	20	77	-94	12	130	-17
30007874	90-390/440	390	440	81	135	147	20	27	-94	12	90	-17
30007875	100-390/440	390	440	81	135	157	20	37	-94	12	100	-17
30007876	110-390/440	390	440	81	135	167	20	47	-94	12	110	-17
30007877	120-390/440	390	440	81	135	177	20	57	-94	12	120	-17
30007878	100-410/460	410	460	81	135	157	20	37	-94	12	100	-17
30007879	110-410/460	410	460	81	135	167	20	47	-94	12	110	-17
30007880	120-410/460	410	460	81	135	177	20	57	-94	12	120	-17

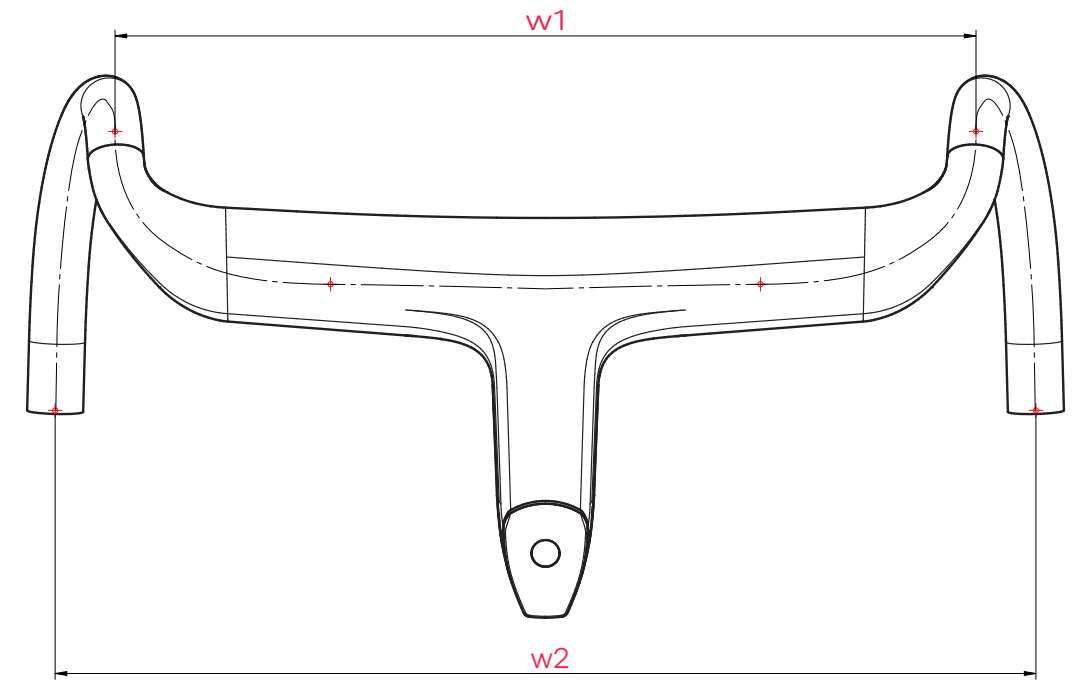



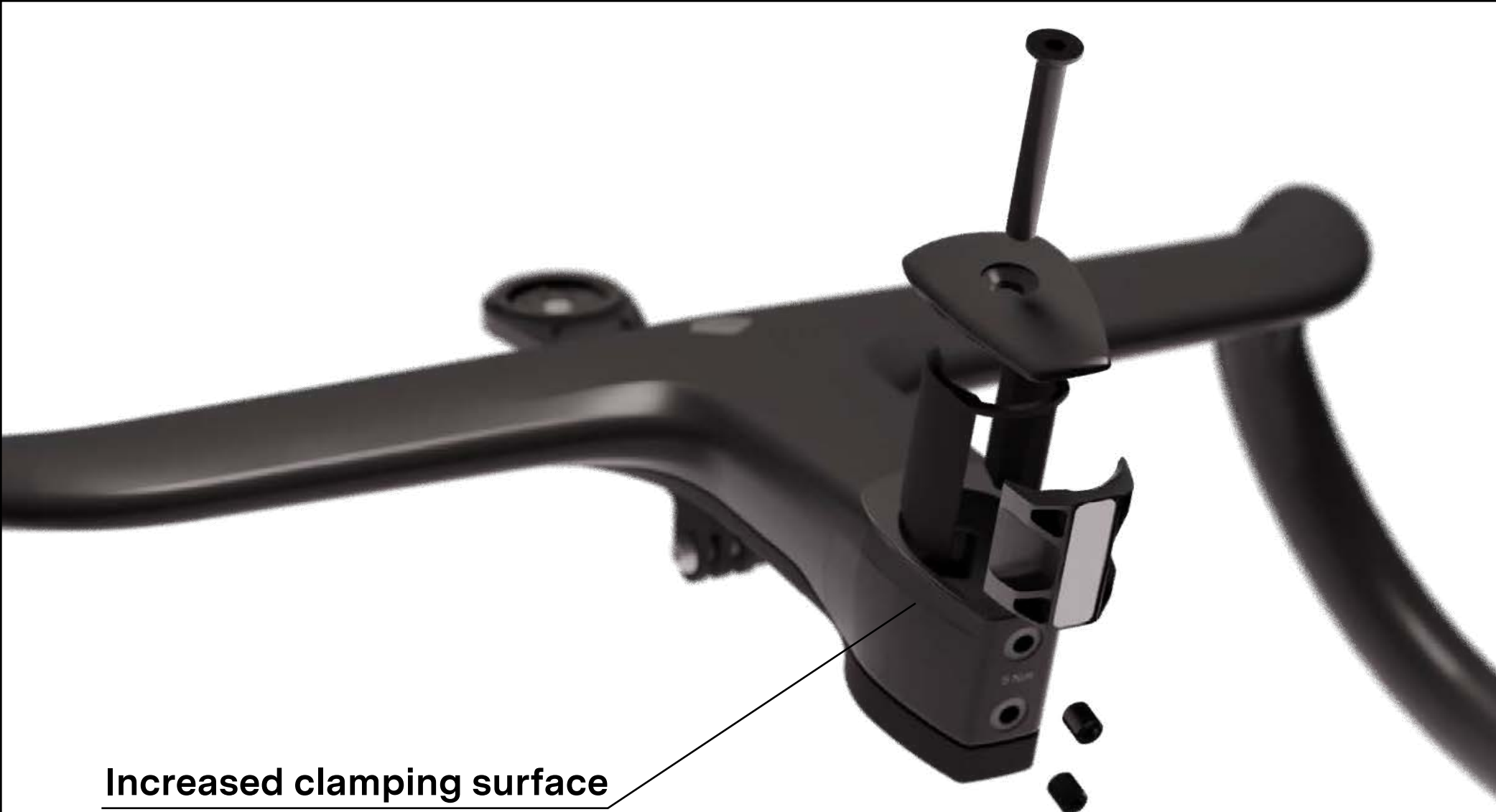

YIN AND YANG
WEIGHT TO STIFFNESS



Increased clamping surface

44mm

		Mpc.	01 Premium
	Without computer mount	395g	408g
	With computer mount, without GoPro mount	425g	438g
	With computer and GoPro mounts	438g	451g

Uncompromised Weight-to-Stiffness

Aero Efficiency, Race-Proven Control.

The ICS Carbon Aero cockpit is the pinnacle of aerodynamic integration and racing ergonomics.

Designed with a “by racers, for racers” approach, this latest cockpit delivers a no-compromise blend of stiffness, weight, and user-focused functionality.

With a contained weight over traditional designs, it delivers twice the stiffness, thanks to an optimized layup of carbon composite and our new steerer clamping system that improves surface contact to the steerer tube for maximum control and power transfer.

This new clamping is 6.5mm higher than the previous design (from 37.5 to 44mm) Thanks to a more aggressive stem angle, your hand position remains unchanged though.

Cable Management - User Friendly

The new, user-friendly design avoids internal cable routing and allows technicians to replace / install the cockpit faster - and makes for happier mechanics.

This becomes handy when going through bike fitting adjustments or -in the unfortunate event of a crash- when you need to change a compromised cockpit.





AEROSYNTHESIS

AeroSynthesis – Rider Included

AeroSynthesis is a design philosophy and technology approach focused on harmonizing aerodynamic performance and system integration in development. BMC is driving the next step of components design combining seamless rider-bike-components integration, advanced computational fluid dynamics (CFD), wind tunnel testing, and real world testing.

Engineered with AeroSynthesis philosophy, this cockpit acts as the leading edge of your system—cutting airflow before it reaches the rider for real aero gains.

The design includes the rider and improve the overall drag by 0.3%. It feels not much but we 0% take this as a win.

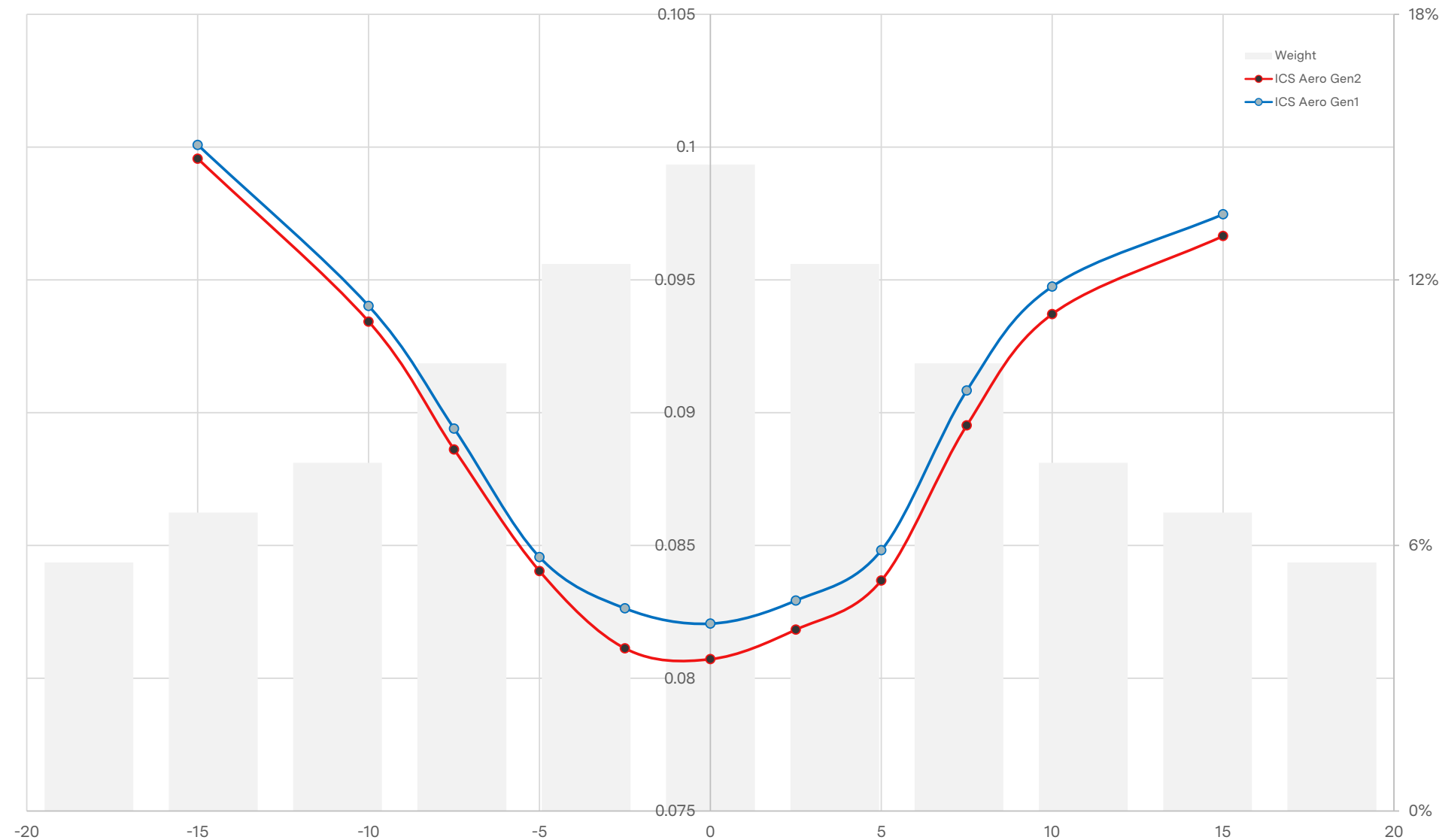

Bike without rider (chart): 1.3% faster
Complete system with rider: 0.3% faster

Silverstone Sports Engineering Hub
45kph riding speed, Complete bike Teammachine R 01 (no rider)

Gen 2

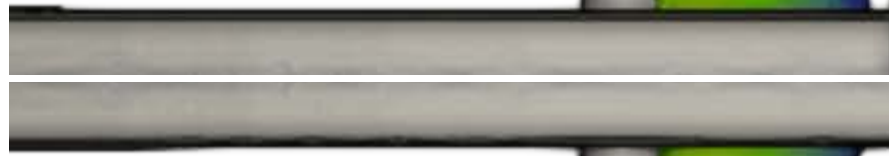

Gen 1

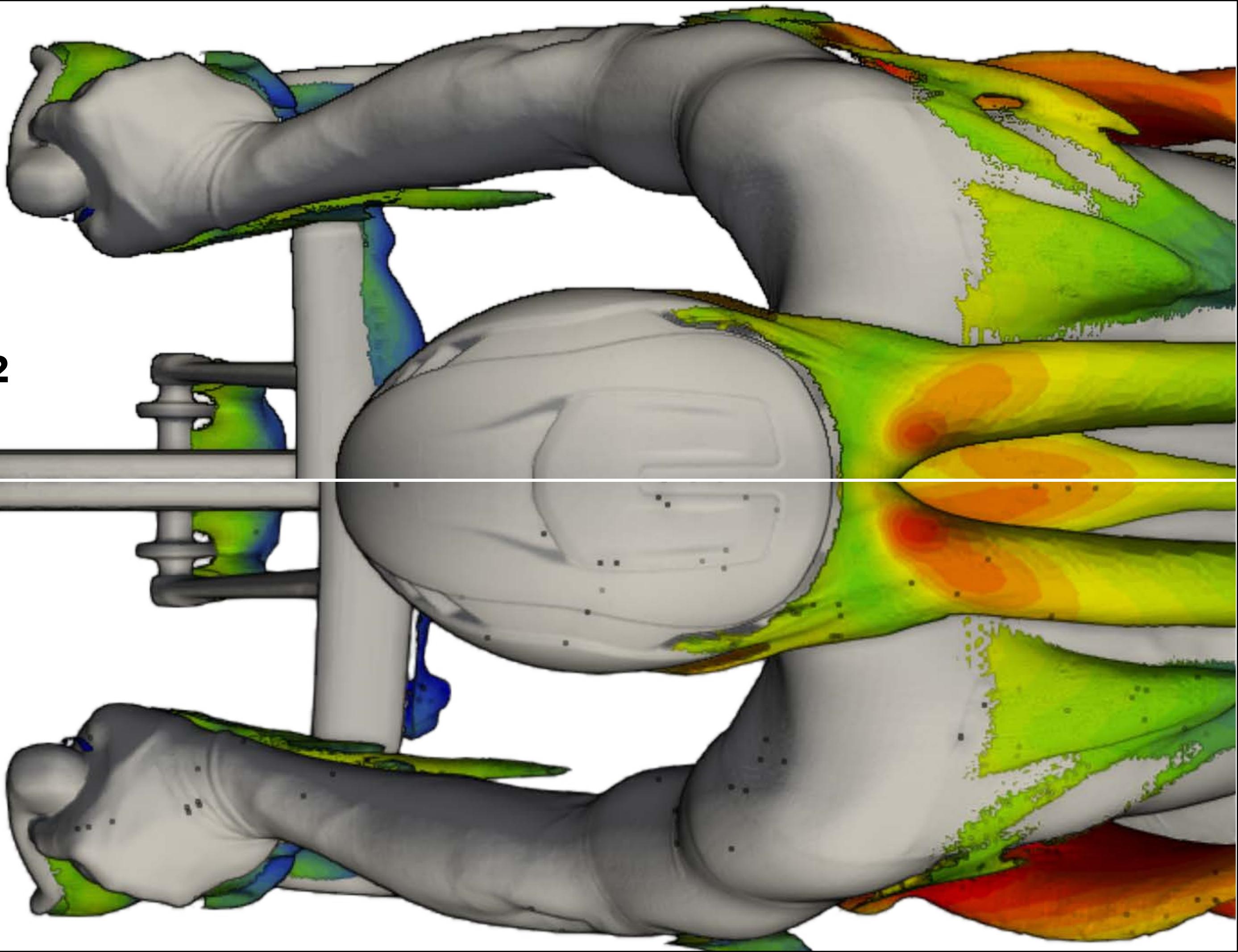

Computer Mount

Delivered with its specific computer mount, the new Aero cockpit is designed to accommodate most cycling computers and GoPro-style mounted accessories.

Both Garmin and Wahoo interfaces are provided.

Choose to ride it without mount, only with the computer mount, or with the full combo computer and GoPro mounts.



	Max weight
Computer only max weight	220g
GoPro only load max weight	200g
Total computer and GoPro max weight	300g

Cockpit ICS2 Carbon Aero Mpc.

MSRP 1250 EUR-USD-CHF

	370/420	390/440	410/460
80			
90	30007862		
100	30007863		
110	30007864		
120	30007865		
130			
140			



Recommended for



Teammachine SLR Mpc.



Teammachine R Mpc.

Cockpit ICS2 Carbon Aero Gen2

MSRP 699 EUR-USD-CHF

	370/420	390/440	410/460
80	30007867		
90	30007868	30007874	
100	30007869	30007875	30007878
110	30007870	30007876	30007879
120	30007871	30007877	30007880
130	30007872		
140	30007873		



Recommended for

Teammachine SLR Series



Kaius 01



Teammachine R Series



Roadmachine Series





QUESTIONS & ANSWERS

Is this new cockpit only available in Mpc. Grade?

Both “Mpc.” and “01 Premium” carbon grades are available.

What are the length and width options available?

- Mpc. is available in one width (370-420) and multiple stem length from 90 to 120mm.
- 01 Premium is available in three different width (370-420, 390/440, 410/460) and multiple stem length from 80 to 140mm.

What is the ASTM category of the cockpit? Can I ride it on gravel terrain with my Kaius gravel bike?

The bar is designed to resist to the constraints and stress of gravel racing. It's ASTM2 compliant.

Is this new design compatible with mechanical shifting cables?

This design supports electronic shifting only, since the cable grooves are engineered exclusively for brake hose routing.

Which computer is compatible with the mount?

All current Garmin computers (incl. Edge 1050) and Wahoo (Incl. Elemnt Ace).

Is the cockpit available in different colors?

The new ICS Carbon Aero cockpit is offered in 14 different size variations, in a black colorway for consumers. Tudor Pro Cycling do use a special red edition, but this was developed exclusively for the team to enhance their visibility in race coverage.

Is it UCI legal?

Yes, all our cockpits comply with latest UCI rules enforced since January 1st of 2026.

What are the key differences between ICS Carbon Aero Gen. 1 and Gen. 2 cockpits?

Generation 1 remains one of the best aero cockpits available on the market. With Generation 2, we deliver even better aerodynamics, increased stiffness, enhanced ergonomics through additional size options, improved brake-lever fit and refined drop shaping, all paired with more user-friendly cable routing.

Is the new cockpit compatible with non- BMC bicycles? Does it work with standard 1 1/8 spacers?

Even if the cockpit could fit a standard 1”1/8 steerer tube, it's not compatible with other cable integration system outside of BMC ICS. It's optimized for the use of ICS2 aero spacers. For compatibility with your frame, please refer to ICS Compatibility Document | MY27 Guide available on our website.

Is there any rider weight limit?

Yes, as with any product, there is a limit. This model is approved for a maximum rider weight of 120 kg.

How much weight can hold the computer mount?

- Max computer weight 220 g (Wahoo Elemnt Ace 208g, Garmin Edge 1050 161g)
- Max GoPro accessory weight 200g (Lezyne Fusion Drive 500+ 128g, Garmin Varia UT800 130g)
- Max total weight (300g)

BMC

BMC