

ICS2 Carbon Aero Cockpit Generation 2

Owner's Manual

BMC

MEMBER

Table of content

Introduction	5
Generalities	5
General notes and warnings	5
Intended use	6
General notes about this manual	6
Before we start	6
Component compatibility	7
Special Parts Details	8
General notes about assembly	10
Torque Recommendations	10
Clamping areas	11
Sizing and parts selection	12
Positioning	12
Cockpit geometry	12
Detailed assembly instructions	15
Recommended assembly procedure	15
Ergonomy and adjustments	15
Cutting the bar	16
Definition of Steerer Tube Length	17
Cutting the Steerer Tube	20
Installing the brake levers	21
Cockpit Installation on the Bike	25
Installing cables, covers, and bar tape	27
Installing Computer Mount and GoPro Mount	28
Headset Compression and Clamping the Stem	29
Service instructions	30
Maintenance	30
Trouble shooting	30
Notes	31

Introduction

Thank you for purchasing your BMC ICS Carbon Aero Cockpit. This cockpit represents the pinnacle of functional integration, and rider-focused fit. By patiently following these guidelines, the content of this manual will lead to properly fitting and functioning equipment with a high-performance, Swiss Engineered aesthetic.

The BMC ICS Carbon Aero Cockpit is designed to provide a very high level of performance. It uses all the latest and most high-end technologies that can be found in bicycle manufacturing, including thin-walled carbon fiber composite construction, which should be treated with care by the end user to prevent permanent and sometimes invisible damage.

For the reasons mentioned above, we ask you to carefully follow the instructions provided in this manual.

Incorrect mechanical operation on your bicycle could lead to serious damage, which could cause you to fall and lead to injury or death.

If you do not have the appropriate tools or experience to execute the following instructions, or if you need further information, please contact your official BMC dealer for service of your bicycle.

Generalities







General Notes and Warnings

You must read and understand the *Safety Instructions* described in the *BMC Owner's Manual* included with your product before proceeding with installation. Improperly installed components are extremely dangerous and could result in severe and/or fatal injuries. If you have any questions about the installation of these components, consult a qualified bicycle mechanic.

 **WARNING:** Indicates a dangerous or hazardous situation. Failure to follow the instructions could result in losing control of the bike or having a component fail. Consequences could be: product damage, injury or death.

 **INFORMATION:** Indicates important information.

This manual uses icons and color codes to indicate actions for proper assembly and adjustments.

 Grease	 Adjust
 Thread locker	 Measure
 Friction Paste	 Cut
 Torque	

Intended Use

The BMC ICS Carbon Aero Cockpit is designed and tested for Road and Gravel riding.

It complies with Level 2 ASTM Classification.

Please read and refer to the general BMC Owner's Manual for more details.

The structural weight limit for the BMC ICS Carbon Aero Cockpit is 110kg / 242lb.

⚠ WARNING: Always make sure to never exceed the structural weight limit with the sum of rider weight, rider's equipment (e.g., helmet, shoes, apparel) and accessories (e.g., bag, clip-ons). Exceeding the structural weight limit may impair the structural integrity of the component and result in damage or failure.

⚠ WARNING: Do not use the product outside of the scope of its intended use. Doing so may exceed the structural resistance of the cockpit and result in component damage or failure.

General Notes About This Manual

Read and keep this manual for your BMC cockpit. It includes essential safety, performance, and technical details. Refer to it before your first ride and store it in a handy place.

This document is specific to the BMC ICS Carbon Aero Cockpit and should be read with the *BMC Operating manual* for the bike you are installing the cockpit on.

Before We Start

The BMC ICS Carbon Aero Cockpit is designed to be compliant and compatible with most of bicycle standards. Please make sure you are fitting it with the right components.

Please refer to the service and assembly instructions detailed in the following chapters of this manual.

Component Compatibility

Shift-brake Levers :

Most of the road dropbar brake levers and brake levers are compatible with the BMC ICS Carbon Aero Cockpit.

We have designed the cockpit to be compatible with the components listed below. Compatibility may change following updates or modifications of the components:

SHIMANO compatible models:

- DURA-ACE, ST-R9270
- ULTEGRA, ST-R8170
- 105, ST-R7170
- 105, ST-R7120
- GRX, ST-RX825
- GRX, ST-RX715
- GRX, ST-RX825
- GRX, ST-RX600
- GRX, ST-RX400

SRAM compatible models:

- RED, ED-RED-E1
- RED, ED-RED-D1
- FORCE, ED-FRC-E1
- FORCE, ED-FRC-D2
- RIVAL, ED-RIV-E1
- RIVAL, ED-RIV-D1
- APEX, ED-APX-D1

CAMPAGNOLO compatible models:

- Super Record 13
- Super Record S Wireless
- Super Record Wireless

⚠ WARNING: Fitting brake levers or brake levers models not listed in this list is still possible as long as it fits $\varnothing 24.0$ tubes and complies with SHIMANO's technical guidelines.

Clip-on and Bags:

This cockpit is specifically designed for pure road racing, so compatibility with clip-on extensions or bags is not intended.

Headset Spacers and Steerer Tube:

Optimized for use with ICS 2 standard (BMC flat steerer tube fork, ICS 2 spacers and ICS 2 top cones).

While it can be mechanically compatible with standard round spacers when cables are externally routed, we do not recommend this configuration due to its impact on overall aesthetics.

The ICS 2 spacer design is commonly found on BMC road and gravel models.

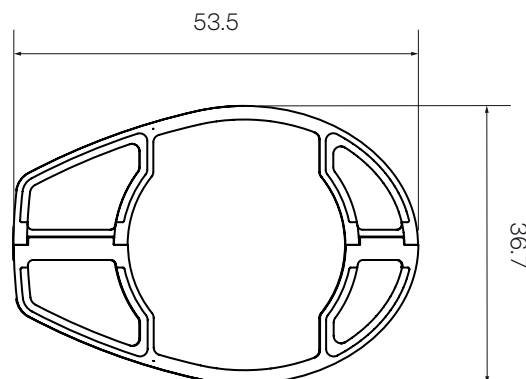

Special Parts Details

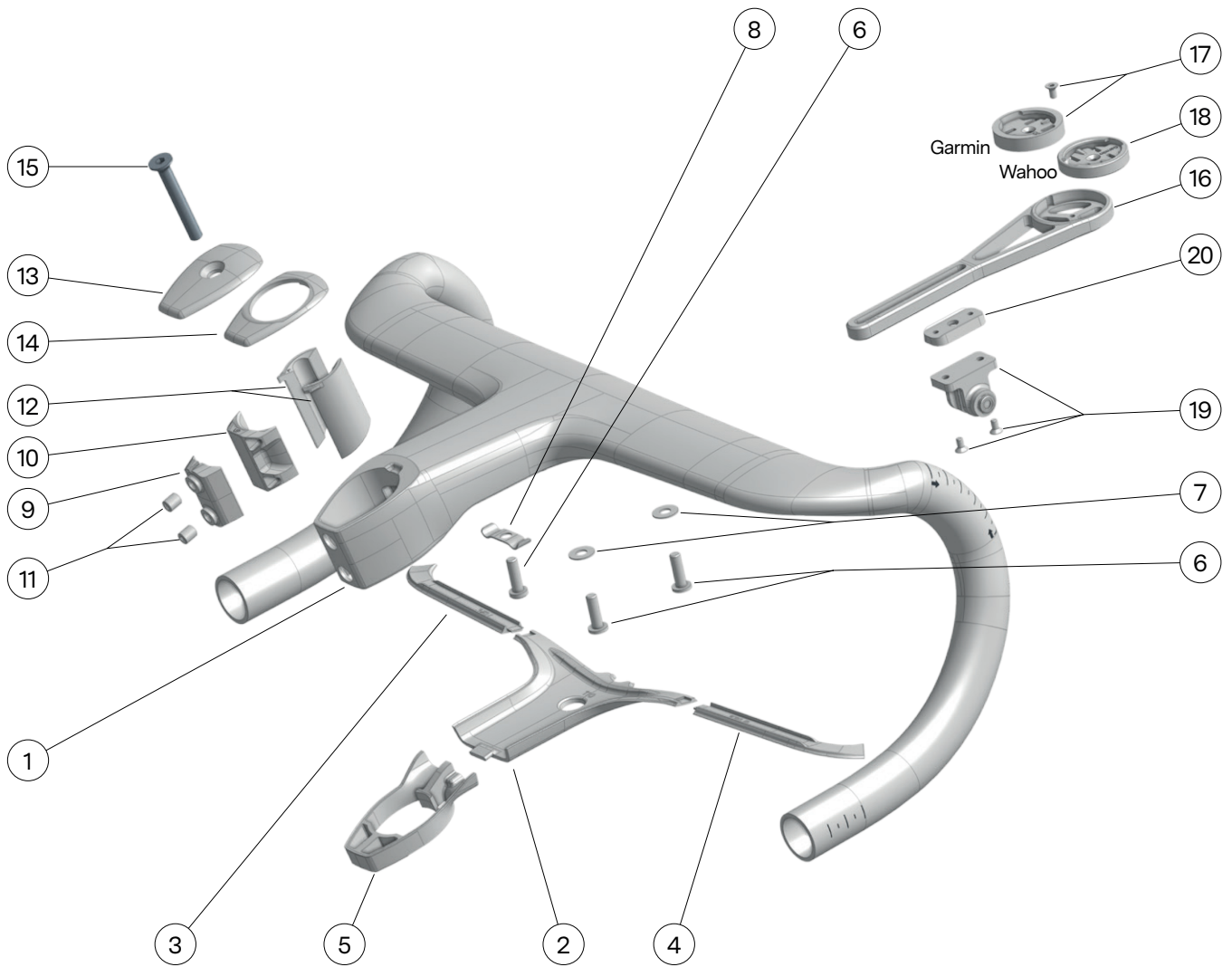

NO. Description/Details

1. ICS Carbon Aero Cockpit Gen2
2. Cable cover
3. Groove Cover Left
4. Groove Cover Right
5. Cable guide
6. Cover bolt, Hex socket head cap screw, low head, M5x16 P0.8
7. Cover bolt washer, M5x12x0.8
8. Cable clamp
9. Clamp threaded insert with magnet
10. Clamp wedge
11. Clamp set screw M6x10 P0.75
12. ICS Flat steerer wedges (left and right)
13. Top cap
14. Top cap open
15. Compression bolt Hex socket flat countersunk head, M6x45 P1.0
16. Computer mount for ICS Carbon Aero Cockpit Gen2
17. Gamin quarter turn insert with M3x5 stainless screw
18. Wahoo quarter turn insert
19. Go-pro mount with 1x M5x20 bolt & nut, 2x M3x6 screws
20. ICS Carbon Aero Cockpit Gen2 GoPro mount adapter

Spare Parts

Cockpit ICS2 Carbon Aero Gen2 Clamp Kit



Article number: 30007881

Contains:

- Clamp threaded insert with magnet
- Clamp wedge with magnet
- 2x Clamp set screw M6x10 P0.75

Cockpit ICS2 Carbon Aero Gen2 Top Cap

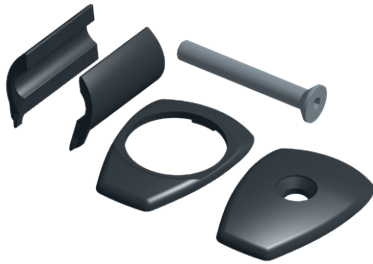

Article number: 30007882

Contains:

- ICS Flat steerer wedges (left and right)
- Top cap
- Top cap open
- Compression bolt Hex socket flat countersunk head, M6x45 P1.0

Cockpit ICS2 Carbon Aero Gen2 Computer Mount



Article number: 30007883

Contains:

- Computer mount for ICS Carbon Aero Cockpit Gen2
- Gamin quarter turn insert with M3x5 stainless screw
- Wahoo quarter turn insert
- Go-pro mount with 1x M5x20 bolt & nut, 2x M3x6 screws
- ICS Carbon Aero Cockpit Gen2 GoPro mount adapter

Cockpit ICS2 Carbon Aero Gen2 Cover Set



Contains:

- Cable cover
- Groove Cover Left
- Groove Cover Right
- Stem cover - Cable guide
- 3x Cover bolt, Hex socket head cap screw, low head, M5x16 P0.8
- Cover bolt washer, M5x12x0.8
- Cable clamp

Article number:

30007884	CKP ICS2 CBN AERO GEN2 CVR 80/370	30007890	CKP ICS2 CBN AERO GEN2 CVR 90/390
30007885	CKP ICS2 CBN AERO GEN2 CVR 90/370	30007891	CKP ICS2 CBN AERO GEN2 CVR 100/390
30007886	CKP ICS2 CBN AERO GEN2 CVR 100/370	30007892	CKP ICS2 CBN AERO GEN2 CVR 110/390
30007887	CKP ICS2 CBN AERO GEN2 CVR 110/370	30007893	CKP ICS2 CBN AERO GEN2 CVR 120/390
30007888	CKP ICS2 CBN AERO GEN2 CVR 120/370	30007894	CKP ICS2 CBN AERO GEN2 CVR 100/410
30007889	CKP ICS2 CBN AERO GEN2 CVR 130/370	30007895	CKP ICS2 CBN AERO GEN2 CVR 110/410
		30007896	CKP ICS2 CBN AERO GEN2 CVR 120/410

General Notes About Assembly

Tools

Bike specific tools are required to perform the assembly of your BMC ICS Carbon Aero Cockpit. We recommend that you have a qualified bicycle mechanic correctly install these components.

Before you start assembling, make sure you are equipped with the following tools:

Torque wrench and bits

- Hex 2, 3, 4, 5 mm

Special tools

- Carbon saw blade Park Tool CSB-1.

Grease compounds:

- Grease gun or grease brush.
- Fine assembly grease.
- LOCTITE® 243 Blue threadlocker.

Operator protection:

- Eye protection
- Hands protection

Torque Recommendations

⚠ WARNING: Respecting and applying the correct torque on fasteners is important for your safety. If too little force is applied the component will not be secure and if too much force is applied the component's structure could deform and break.

Therefore, not respecting the torque specification of any component could result in failure, which can cause loss of control and a fall.

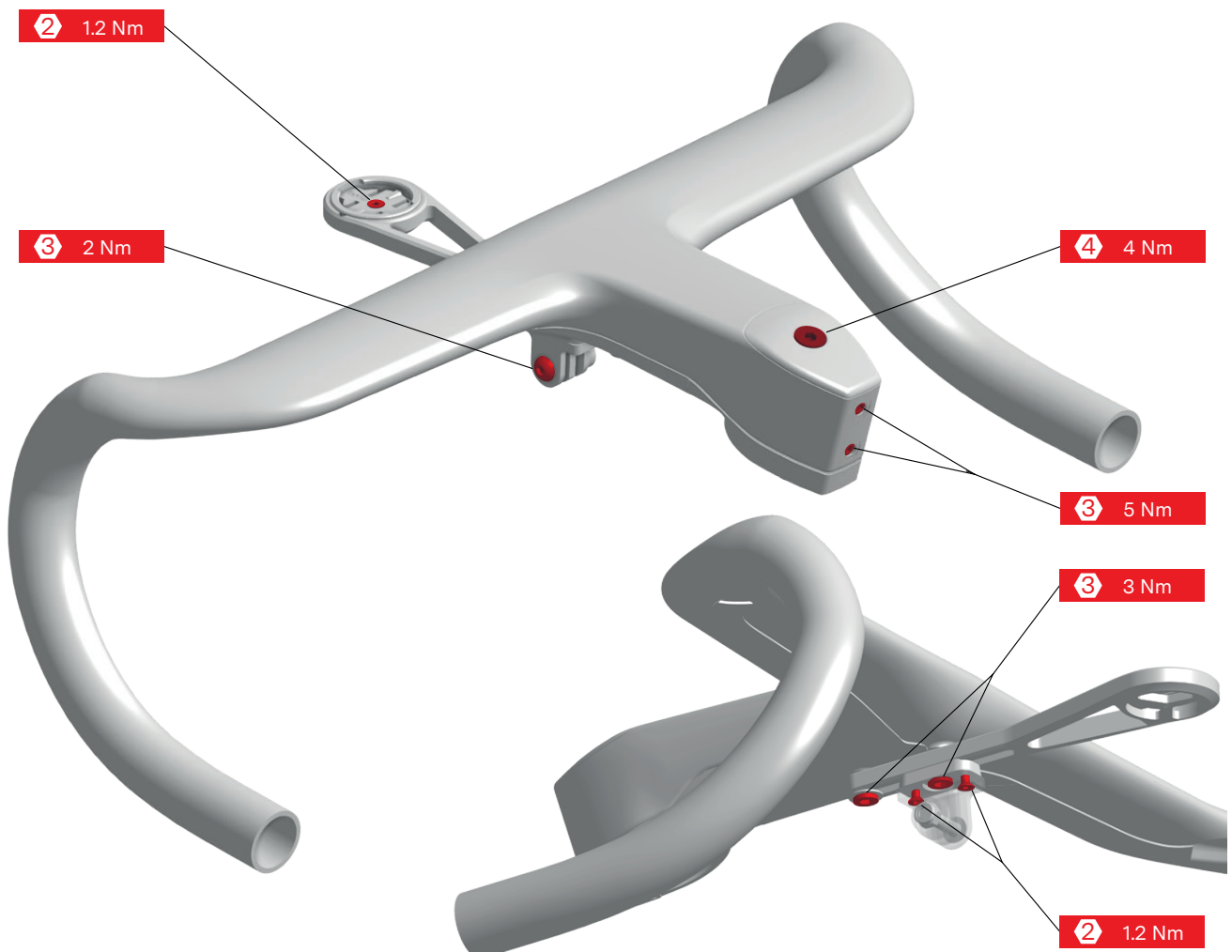

Sizing and Parts Selection

Positioning

A bicycle rider will only perform at their best if they are correctly positioned on their bike. Please refer to the geometry table below to find the best cockpit length for you.

Cockpit Geometry

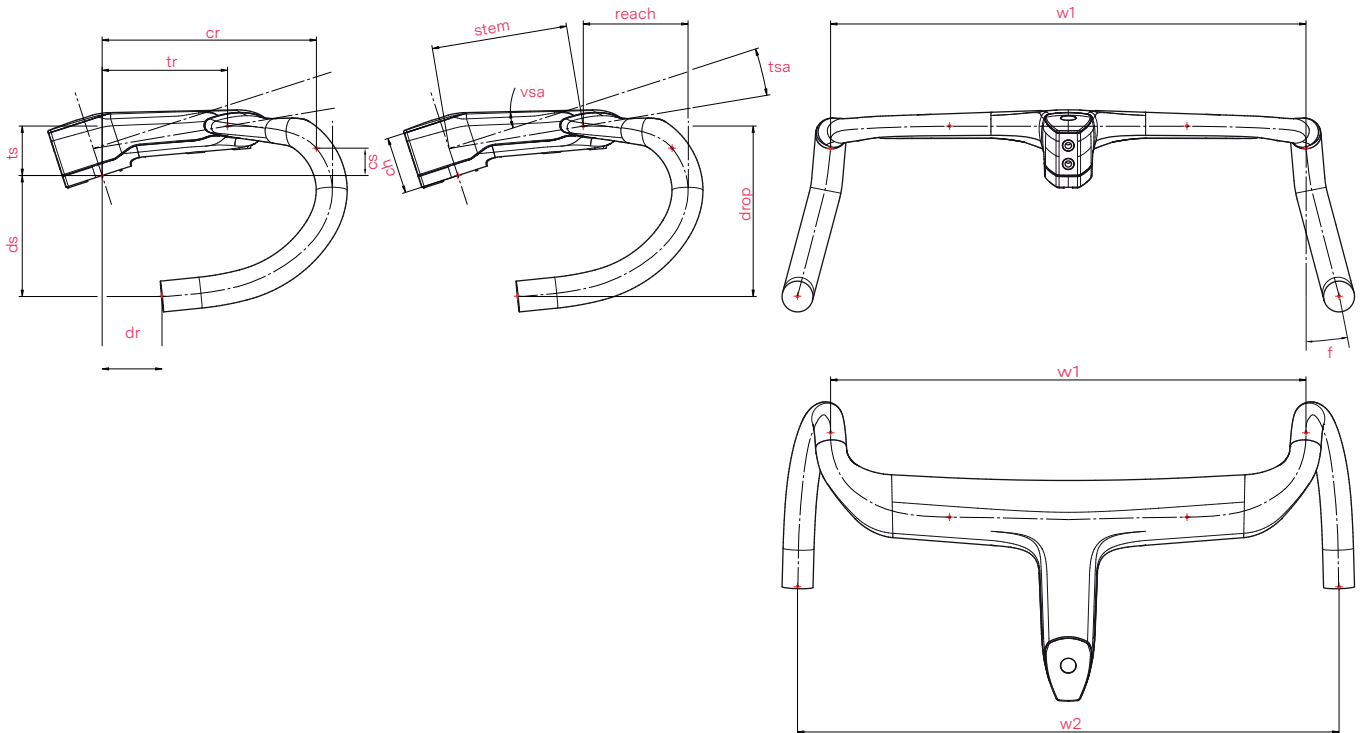

ICS2 Carbon Aero Mpc.

Commercial name	ICS2 Carbon Aero Mpc.			
Size	90-370/420	100-370/420	110-370/420	120-370/420
Width at hoods (w1)	370	370	370	370
Width at Drops (w2)	420	420	420	420
Handlebar Reach (reach)	81	81	81	81
Handlebar Drop (drop)	135	135	135	135
Clamping point Reach (cr)	147	157	167	177
Clamping point Stack (cs)	20	20	20	20
Drops Reach (dr)	27	37	47	57
Drops Stack (ds)	-94	-94	-94	-94
Tops Reach (tr)	77	87	97	107
Tops Stack (ts)	38	38	38	38
Drop Flare (f)	12°	12°	12°	12°
Stem Length (stem)	86	96	106	116
Visual stem angle (vsa)	-17°	-17°	-17°	-17°
Technical stem angle (tsa)	-7°	-8°	-8°	-9°

ICS2 Carbon Aero Gen2

Commercial name	ICS2 Carbon Aero Gen2				
Size	80-370/420	90-370/420	100-370/420	110-370/420	120-370/420
Width at hoods (w1)	370	370	370	370	370
Width at Drops (w2)	420	420	420	420	420
Handlebar Reach (reach)	81	81	81	81	81
Handlebar Drop (drop)	135	135	135	135	135
Clamping point Reach (cr)	137	147	157	167	177
Clamping point Stack (cs)	20	20	20	20	20
Drops Reach (dr)	17	27	37	47	57
Drops Stack (ds)	-94	-94	-94	-94	-94
Tops Reach (tr)	67	77	87	97	107
Tops Stack (ts)	38	38	38	38	38
Drop Flare (f)	12°	12°	12°	12°	12°
Stem Length (stem)	76	86	96	106	116
Visual stem angle (vsa)	-17°	-17°	-17°	-17°	-17°
Technical stem angle (tsa)	-5°	-7°	-8°	-8°	-9°

Commercial name	ICS2 Carbon Aero Gen2						
Size	90-390/440	100-390/440	110-390/440	120-390/440	100-410/460	110-410/460	120-410/460
Width at hoods (w1)	390	390	390	390	410	410	410
Width at Drops (w2)	440	440	440	440	460	460	460
Handlebar Reach (reach)	81	81	81	81	81	81	81
Handlebar Drop (drop)	135	135	135	135	135	135	135
Clamping point Reach (cr)	147	157	167	177	157	167	177
Clamping point Stack (cs)	20	20	20	20	20	20	20
Drops Reach (dr)	27	37	47	57	37	47	57
Drops Stack (ds)	-94	-94	-94	-94	-94	-94	-94
Tops Reach (tr)	78	88	98	108	88	98	108
Tops Stack (ts)	38	38	38	38	38	38	38
Drop Flare (f)	12°	12°	12°	12°	12°	12°	12°
Stem Length (stem)	86	96	106	116	96	106	116
Visual stem angle (vsa)	-17°	-17°	-17°	-17°	-17°	-17°	-17°
Technical stem angle (tsa)	-7°	-8°	-9°	-9°	-8°	-9°	-9°

Detailed Assembly Instructions

Recommended Assembly Procedure

The most convenient way is to follow the order and the procedure described below. This is only the general procedure, all the separate steps and recommendations are described one by one in the following pages of this manual.

Recommended steps:

1. Cutting the bar
2. Definition of Steerer Tube Length
3. Cutting the Steerer Tube
4. Installing the Brake Levers
5. Cockpit Installation on the Bike
6. Installing Cables, Covers, and Bar Tape

ⓘ INFORMATION: Please go through all the instructions before starting. Following this sequence will help you save time and facilitate the assembly.

Ergonomy and Adjustments

The BMC ICS Carbon Aero Cockpit has been designed with a wide range of stack and brake levers adjustments in mind. All to ensure your perfect fit.

You should consider adjusting your cockpit for every hand position:

- hand position at tops
- hand position on brake levers hoods
- hand position in drops
- brake levers access

Ideally, please fit the cockpit and brake levers with a bike fitter. It will guarantee the best ergonomic and mechanical setup.

Cutting the Bar

⚠ WARNING: Wear safety equipments and use proper carbon tools. Do not use a pipe cutter, grinder, standard saw blade or any other cutting tool not designed for carbon cutting.

ℹ INFORMATION: Use a saw guide like the Park Tool SG-6 Threadless Saw Guide and an appropriate carbon specific saw blade such as the Park Tool CSB-1.

1. Identify the length of cockpit tube you wish to cut and use electrical tape to protect and delimit the tube you want to keep.
2. Place the saw guide on the cockpit end and align it with the bar tape edge.
3. Carefully cut the tube with a carbon saw.
4. Clean the carbon dust with a cloth.
5. Clean the freshly cut edge with fine sand paper.

⚠ WARNING: Do not drill into or modify the cockpit outside of the authorized areas in anyway. Doing so will void the warranty. Drilling or modifying the cockpit will compromise its structure and could result in failure, which can cause loss of control and a fall.

■ Cutting Areas

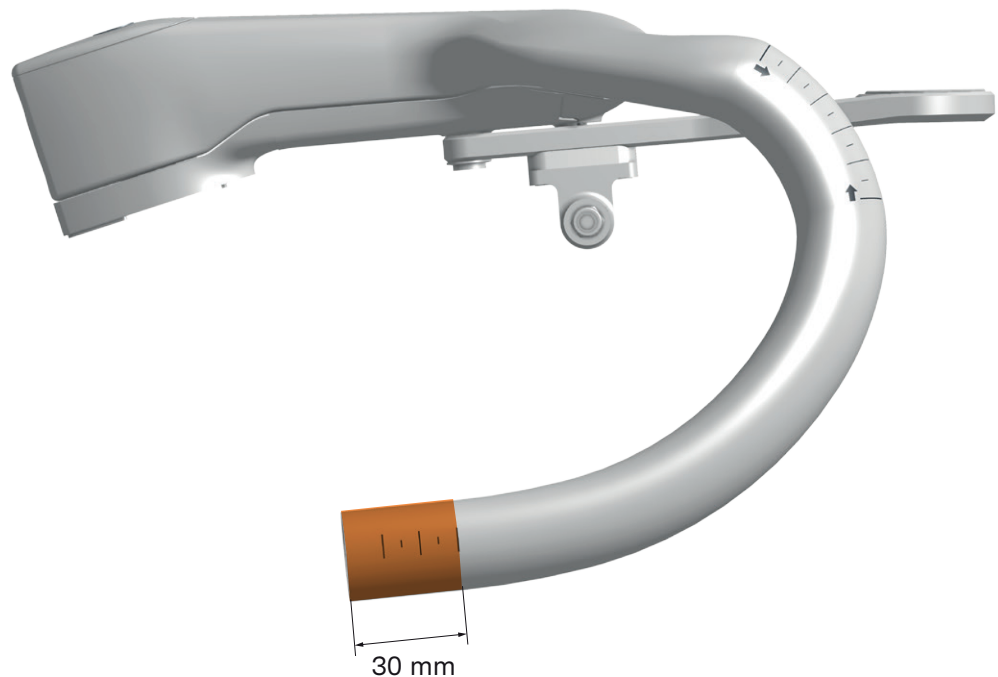

Definition of Steerer Tube Length

Cockpits and Stems Parts Selection

1. Refer to the following illustrations to identify each component required to define the steerer tube length.

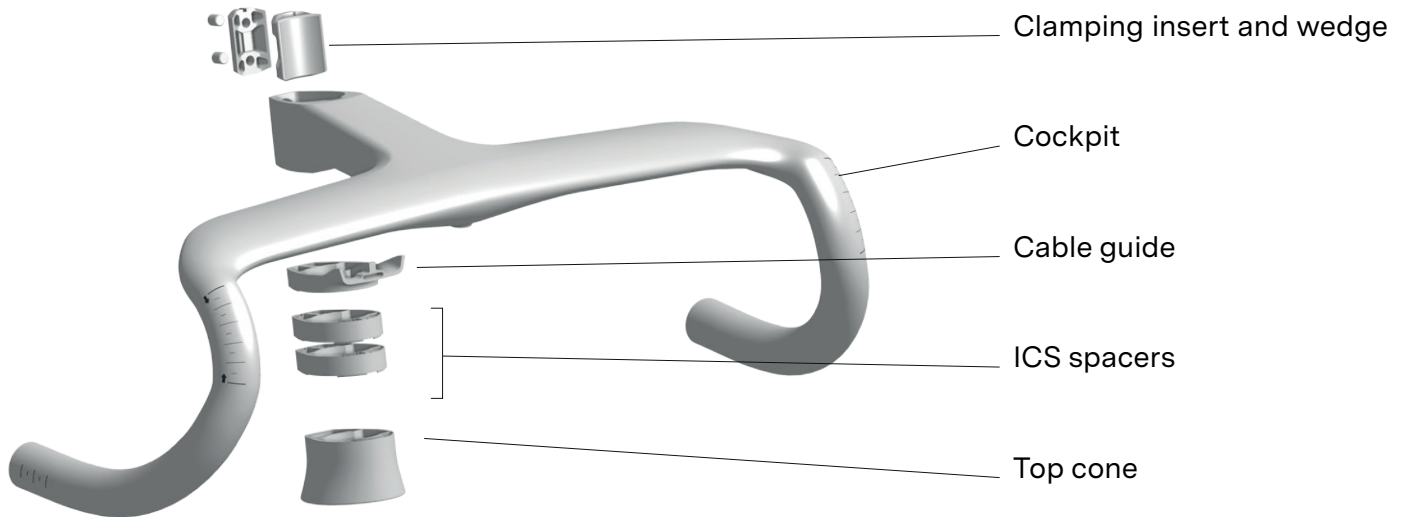

Minimum and Maximum Spacer Stack

1. Determine the stack height based on the rider’s initial or desired position.

⚠ WARNING: The steerer tube should be cut to the correct length for optimal mechanical function and aesthetics.

⚠ WARNING: do not exceed the spacer height and spacer count. Failure to follow these recommendations may result in steering issues resulting in losing control of the bike and a potential crash.

Carbon Aero Cockpit Gen 2		
Top cone	#1 Low [or] #2 High	
Spacer type	ICS	
Spacer max quantity	Cable guide + 2 spacers	
Stack options	Lowest	Highest
Stack height	15mm	60mm
Cable guide	10mm	10mm
Spacers		2x 10mm
Top cone	#1 Low (5mm)	#2 High (30mm)



ⓘ INFORMATION: The BMC ICS Carbon Aero Cockpit is designed to match specific BMC ICS 2 spacers.

While the cockpit may be compatible with standard or other shape of spacers, the clamping interface may not provide a visually seamless fit.

2. Install the headset components to determine the cutting length of the steerer tube:
 - 2.1. Fork
 - 2.2. Lower bearing
 - 2.3. Upper bearing
 - 2.4. Compression ring
 - 2.5. Top cone
 - 2.6. Spacers
 - 2.7. Cockpit stem cover (cable guide)
 - 2.8. Cockpit
 - 2.9. Clamping wedge

3. Clip the right and left sides of each spacer by sliding them into place on top of one another.

■ Align and clip

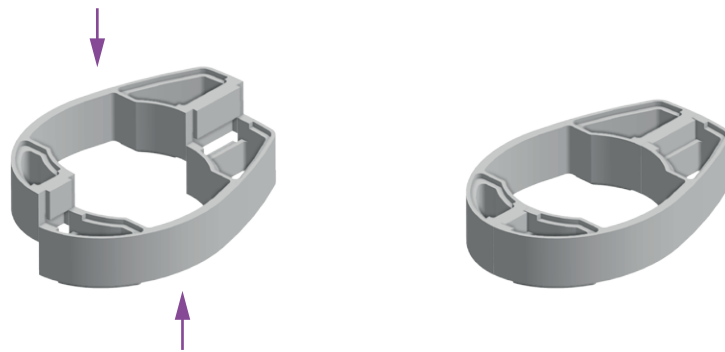

4. Align the different elements to achieve the desired stack.
5. Gently compress the system together and tighten lightly the cockpit to the steerer tube.

INFORMATION: No grease is necessary at this stage.

Pre-assemble all components



 compress

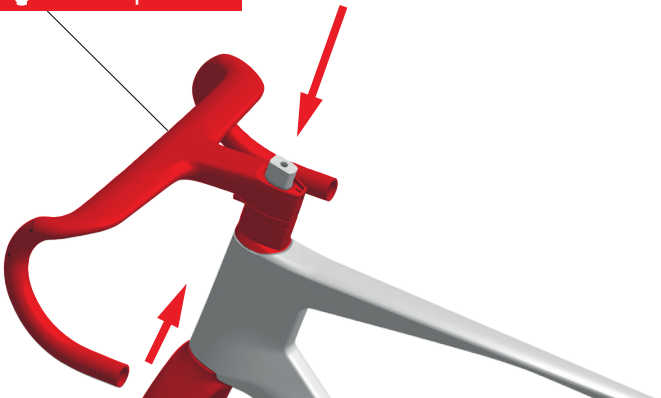

- Control the handlebar stack and reach to make sure the setup is matching your bike fit coordinates.
- Using a silver or white marker pen, make a mark on the steerer tube at the top of the cockpit.

- Clamp reference surface
- Mark the steerer at top of clamp

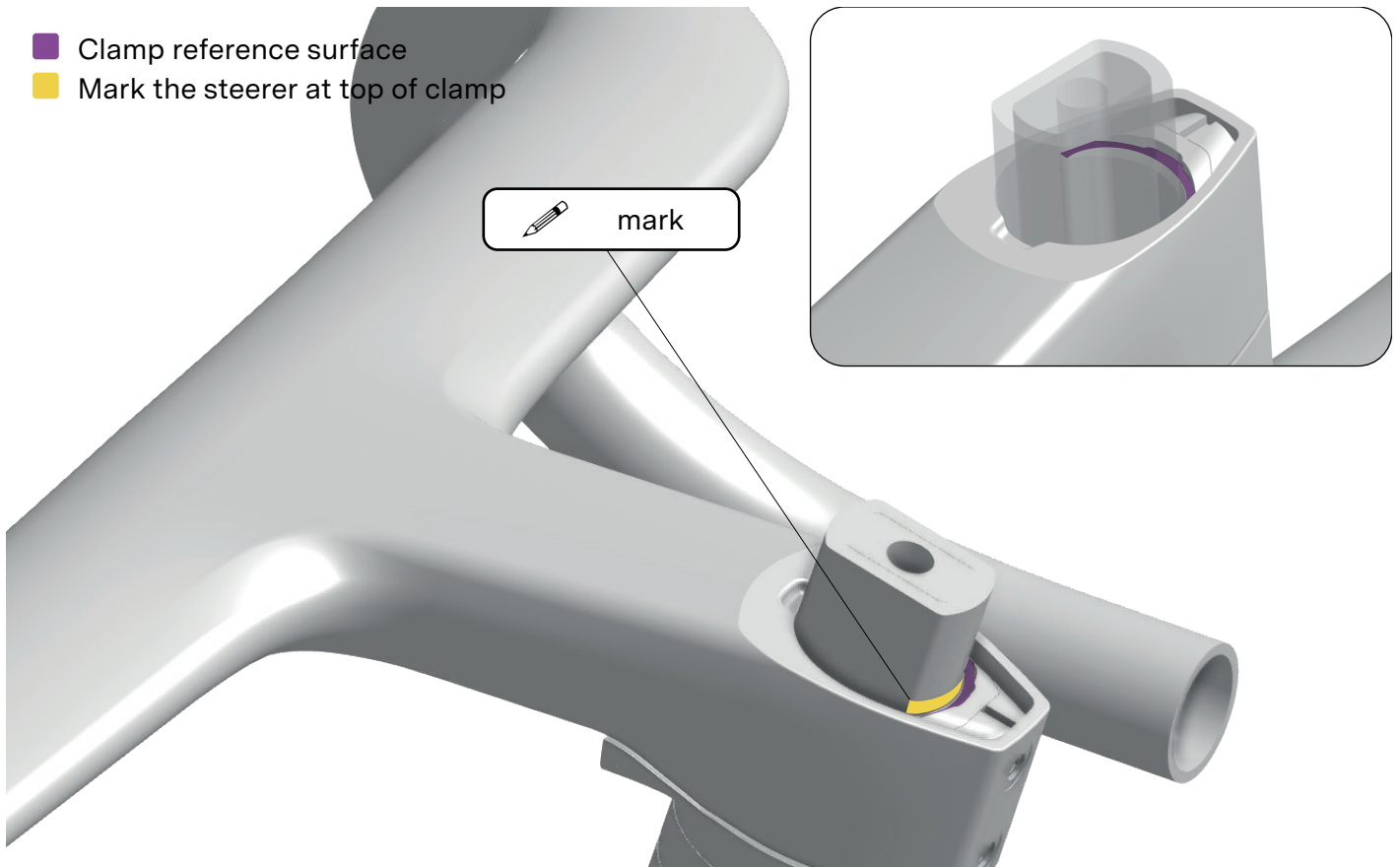

- Uninstall the fork and headset from the frame.

Cutting the Steerer Tube

⚠ WARNING: The steerer tube must be cut between 1 and 2mm below the clamp upper surface to allow for proper headset compression and preloading.

⚠ WARNING: Make sure that the Flat Steerer Expander Bolt is removed from the fork to avoid cutting it with the steerer tube.

1. From the previously marked line, measure and mark a new cutting line 2mm lower.
2. Cut the steerer tube using a suitable tool, as recommended by the fork manufacturer.
3. Install the star-nut in the steerer tube as recommended by the fork manufacturer.
4. Clean the steerer tube surfaces.

■ Report cutting length

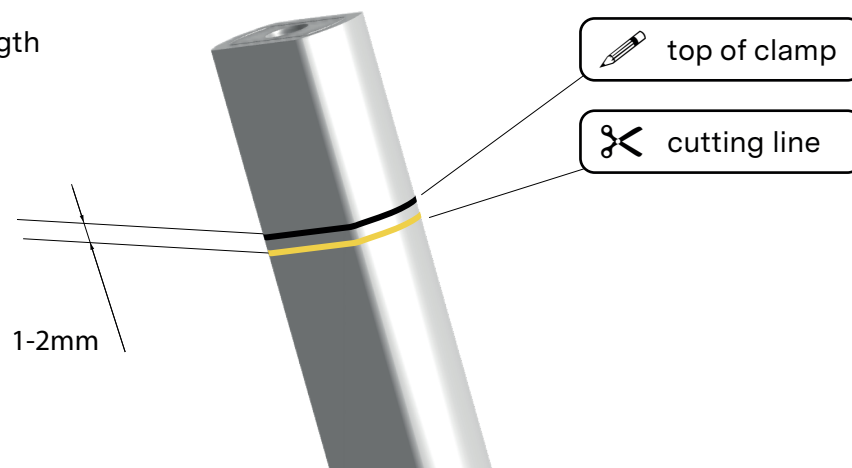

■ Reference surfaces

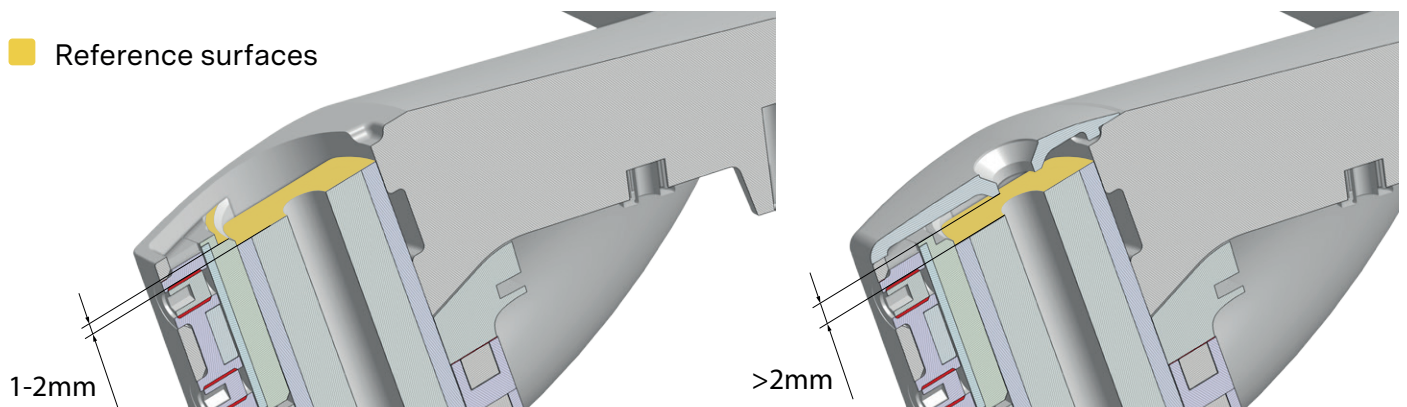

ℹ INFORMATION: Applying tape underneath the cutting line will help guide the saw blade and reduce the risk of carbon delamination.

ℹ INFORMATION: Use a saw guide and an appropriate carbon-specific saw blade, such as the Park Tool CSB-1.

Installing the Brake Levers

⚠ WARNING: Before starting the installation of the shifter-brake levers, inspect the handlebar for any surface defect. Any damage can cause stress and lead to failure, and possible injury or death.

Shift-lever Adjustment Limits

1. Shift-brake levers must be adjusted and clamped within a precise range of adjustments. This range allows you to orient the brake lever up and down alongside the bar drop:
 - 1.1. Levers on a high position: increase the stack and gives the hoods a more upright hand contact surface.
 - 1.2. Levers on a low position: decrease the stack and gives the hoods an horizontal or negative hand contact surface.

Note that some brake levers feature a reach adjustment allowing for ideal access to the brake lever when riding in the drops.

Clamping Zone

⚠ WARNING: No hard part of the brake lever, except the rubber hood, should contact the handlebar outside the green-marked area.

Do not have any part of the brake lever body or clamp in contact outside of the marked area. Do not exceed the MAX graphics.

⚠ WARNING: Brake levers must be clamped only within the area indicated by the markings, highlighted in green.

Ensure that no part of the brake lever body or clamp extends beyond or contacts any area outside the green-highlighted bend.

Not respecting this recommendation could result in failure, which can cause loss of control and a fall.

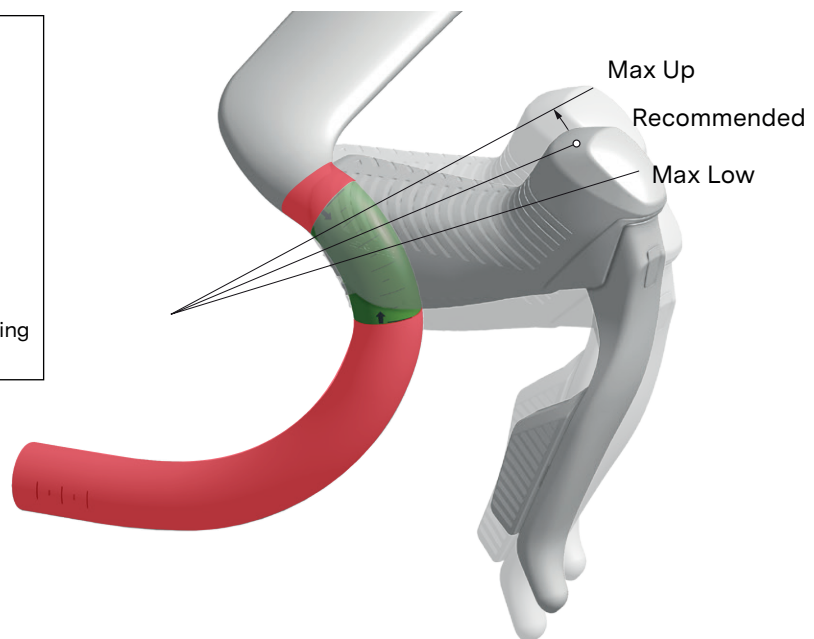
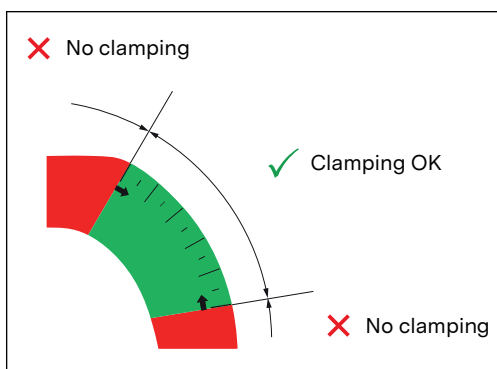

⚠ WARNING: Clamping the brake levers exceeding the limits indicated with “MAX” and a arrow graphic may apply an excessive amount of stress on parts of the handlebar not designed to sustain it. This could result in failure. It may as well generate instability in the brake lever stability. All can cause loss of control and a fall.

Shift-brake Lever Orientation

The brake lever alignment with the handlebar drop is a critical adjustment that insure safety of braking system operation and structural safety for your handlebar.

Do not exceed an angle of $\pm 10^\circ$ of brake lever orientation inward or outward of the drop plane.

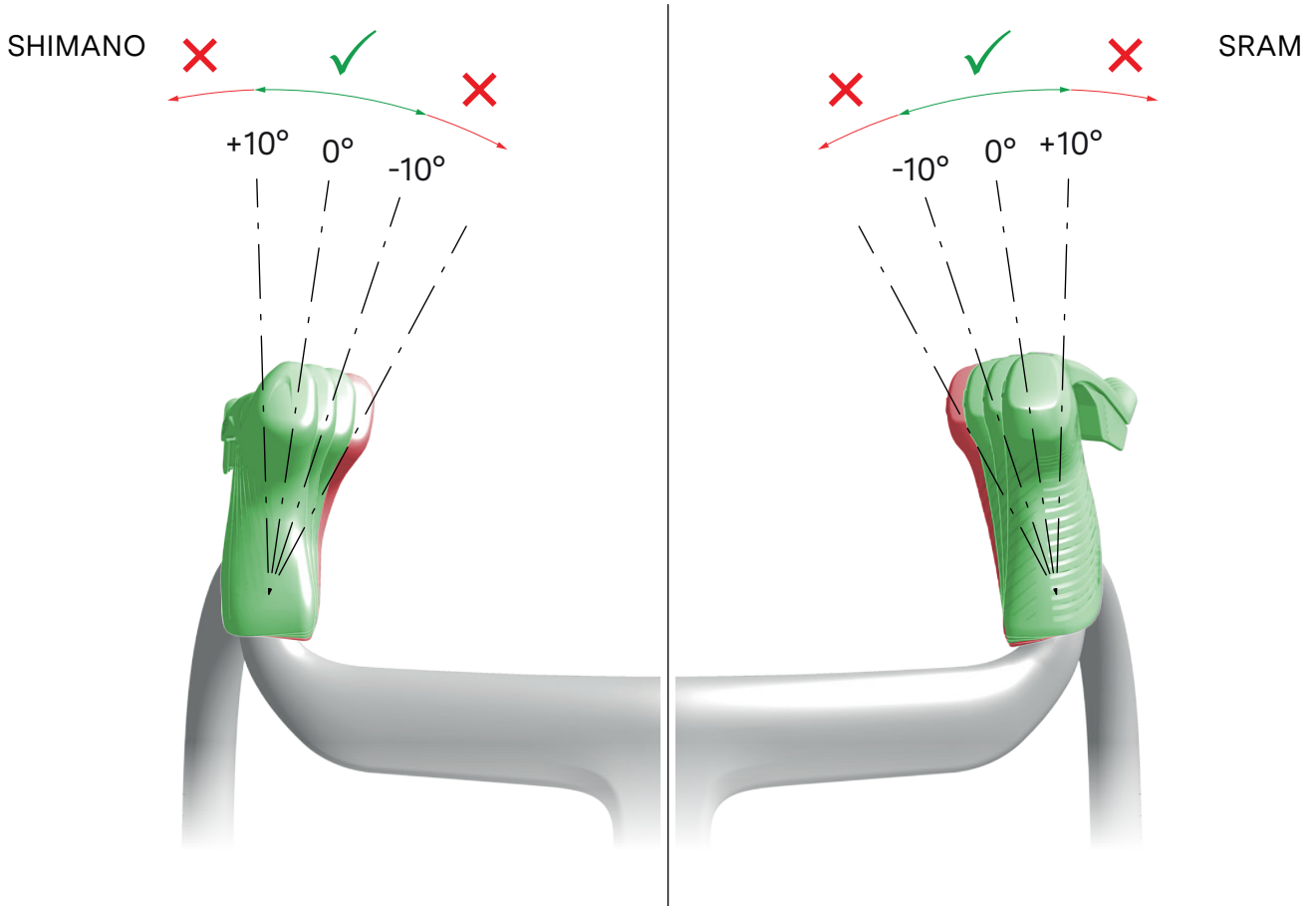

⚠ WARNING: Exceeding the recommendation of the brake lever and drop orientation may apply an excessive amount of stress on the drops of the handlebar. This could result in failure. It may as well generate instability in the brake lever stability. All can cause loss of control and a fall.

ℹ INFORMATION: This recommendation aligns with the “UCI brake hood body inclination” rule as stated in ARTICLE 1.3.022 of CLARIFICATION GUIDE OF THE UCI TECHNICAL REGULATION version 10.01.2024.

Shift-lever installation

⚠ WARNING: Always follow the brake lever manufacturer's instructions.

⚠ WARNING: Before installing the brake lever, inspect the component for any sharp edge or burrs. Inspect the handlebar drop for any surface defect. Any damage can cause stress and lead to failure, and possible injury or death.

⚠ WARNING: Do not rotate or twist the brake lever onto the handlebar drop if you have already significantly tightened the clamp as this motion can scratch or damage the handlebar drops surface or fragilize its structure. This could result in failure, which can cause loss of control and a fall.

⚠ WARNING: Always respect the recommended tightening torque instructed by the lever manufacturer.

1. Loosen the brake lever clamps to allow the shif-brake levers to easily slide on the bar drops. Consider to even disconnect completely the lever clamp to the body to ease the installation even more.
2. Clean the brake lever and handlebar contact surfaces and apply friction paste (optional).

■ Friction paste

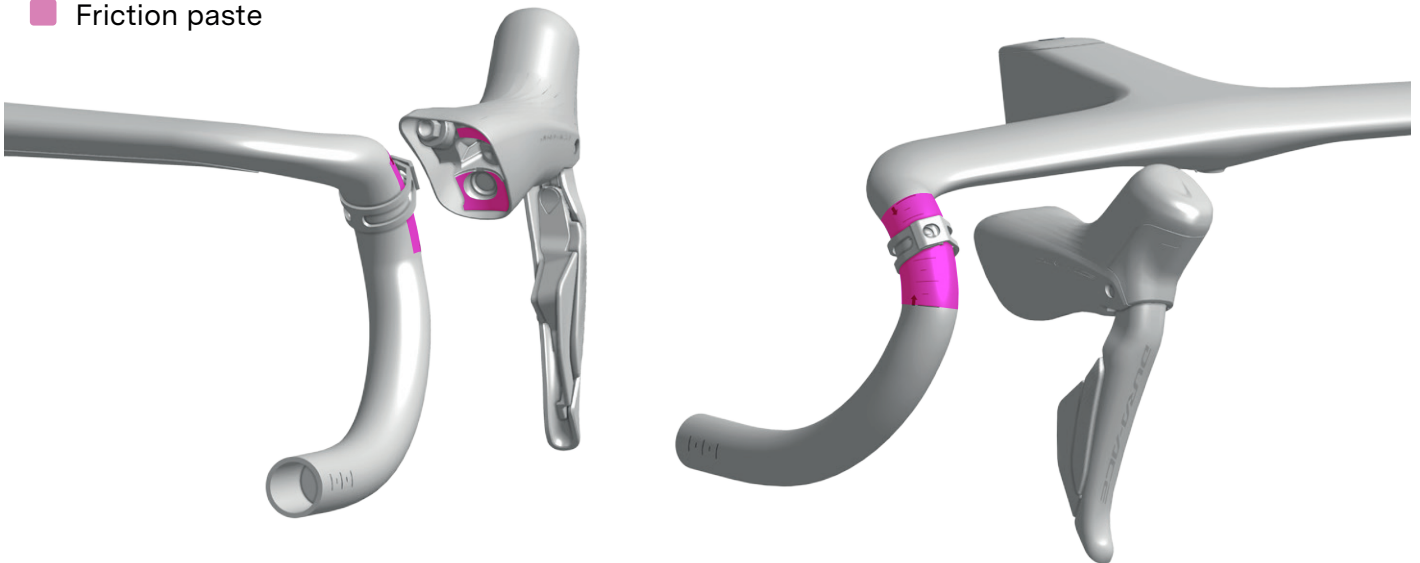

3. Slide the brake levers onto the drops and position them at the desired position.
4. Start to tighten the brake lever clamp slightly to fine tune its position on the handlebar according to your fit preferences.
5. Align both brake levers and check their symmetry.
6. Clamp the brake levers to the manufacturer's instructions.

ⓘ INFORMATION: If not yet assembled to the bike, consider placing the handlebar with assembled brake levers onto a table top. In this configuration, you can easily align the tips of the levers and make sure about their symmetry.

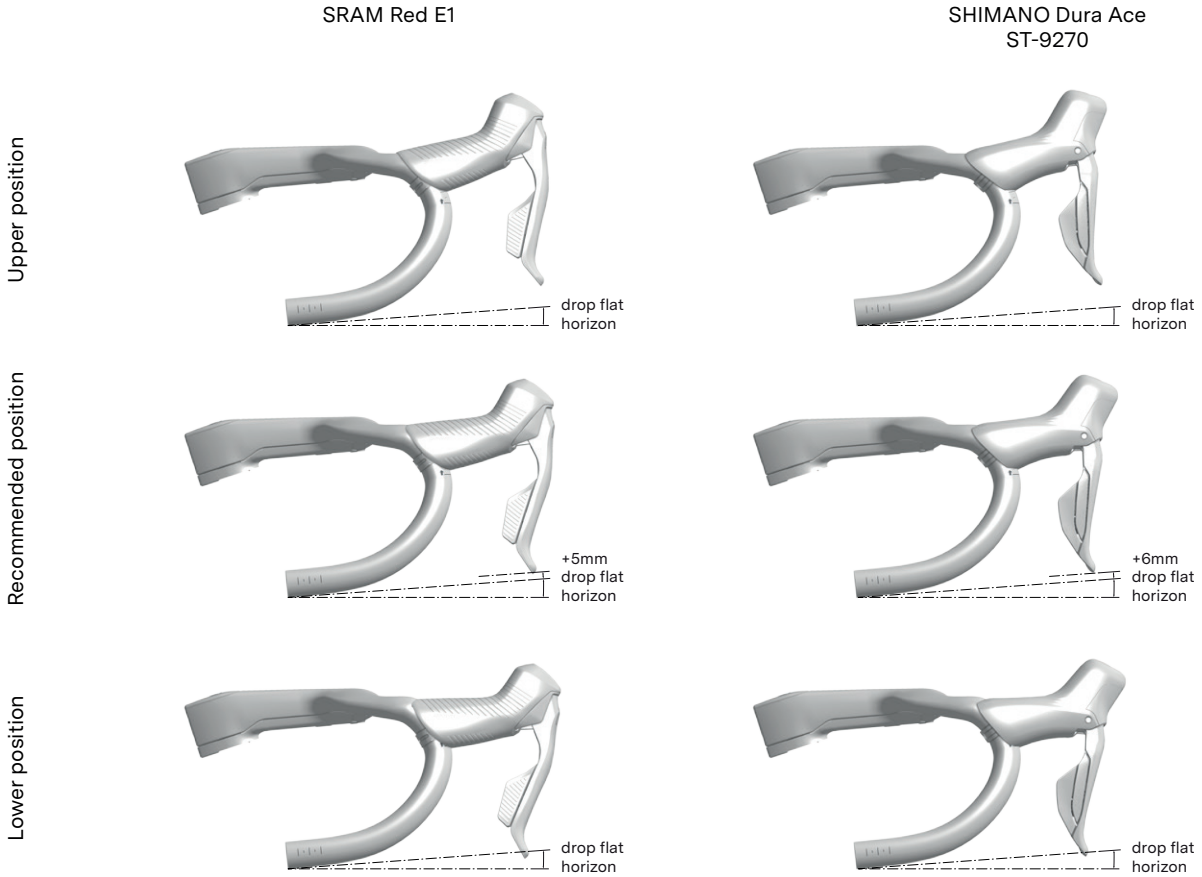

We recommend the standard position illustrated bellow as a starting point.

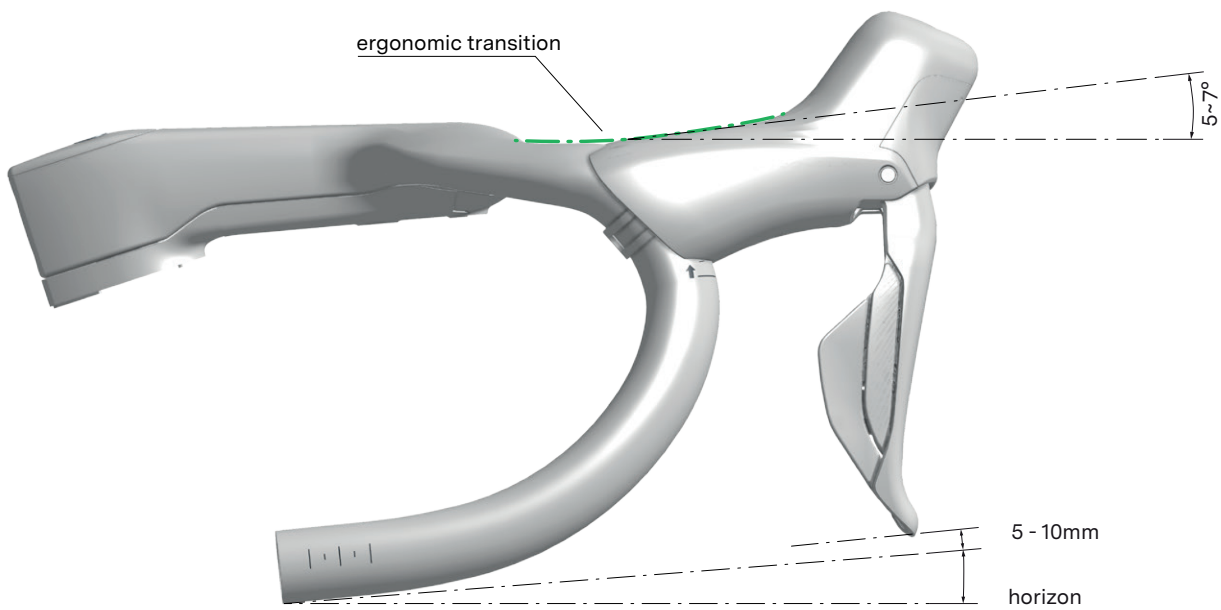

Cockpit Installation on the Bike

Cable Routing

1. You must anticipate and prepare the brake hose routing in advance to ensure each hose is positioned on the correct side, according to your brake lever setup and preferences.
2. Follow the table instructions to route each hose on the correct side of the steerer tube.

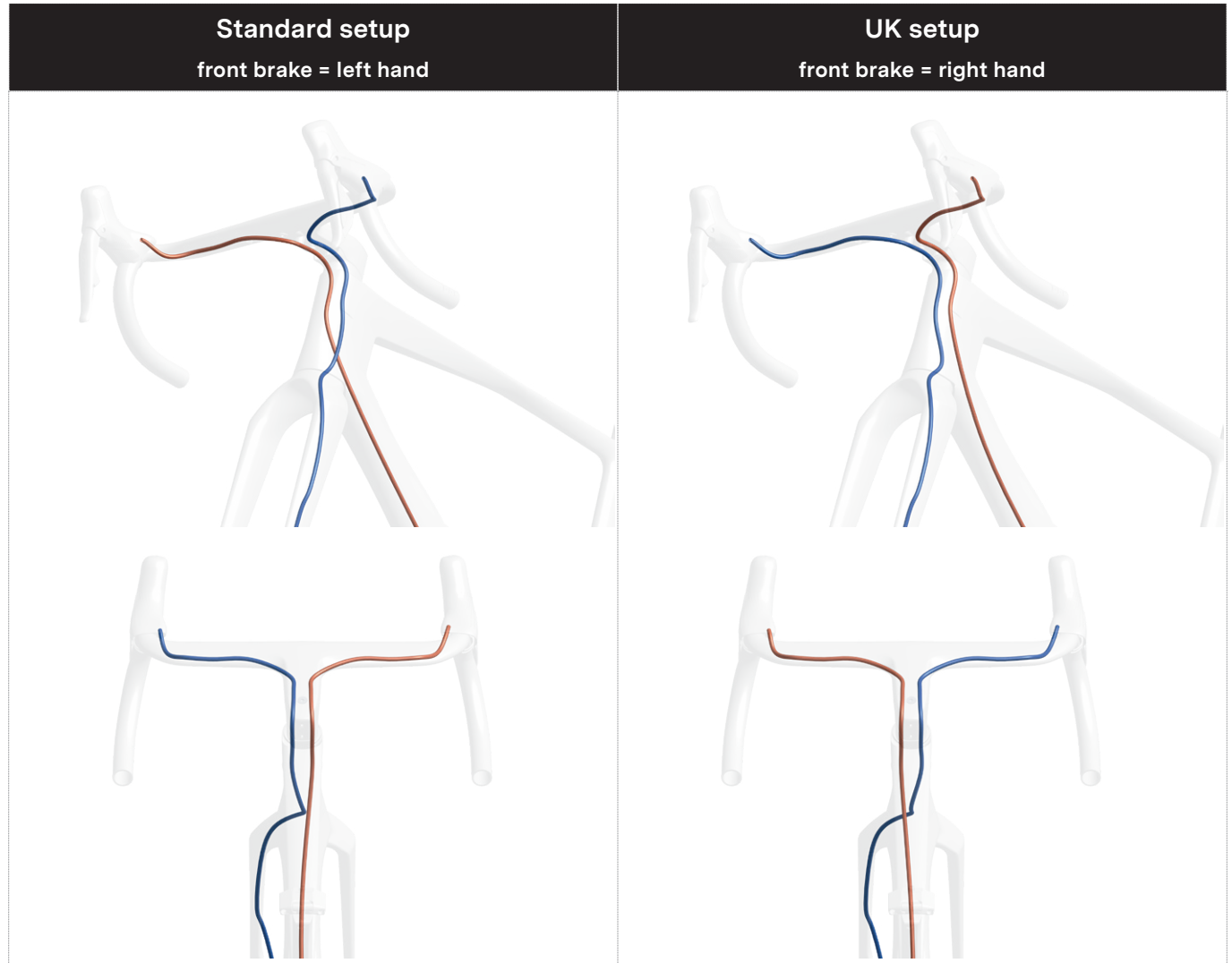

Assembling All Elements

1. Compile the different elements of the stem/handlebar or cockpit as determined in “Definition of Steerer Tube Length” on page 14.

⚠ WARNING: Do not tighten the stem steerer clamping bolts without the ICS flat steerer wedges. Tightening the stem steerer clamping bolts can compromise the integrity of the steerer tube – leading to failure and serious injury.

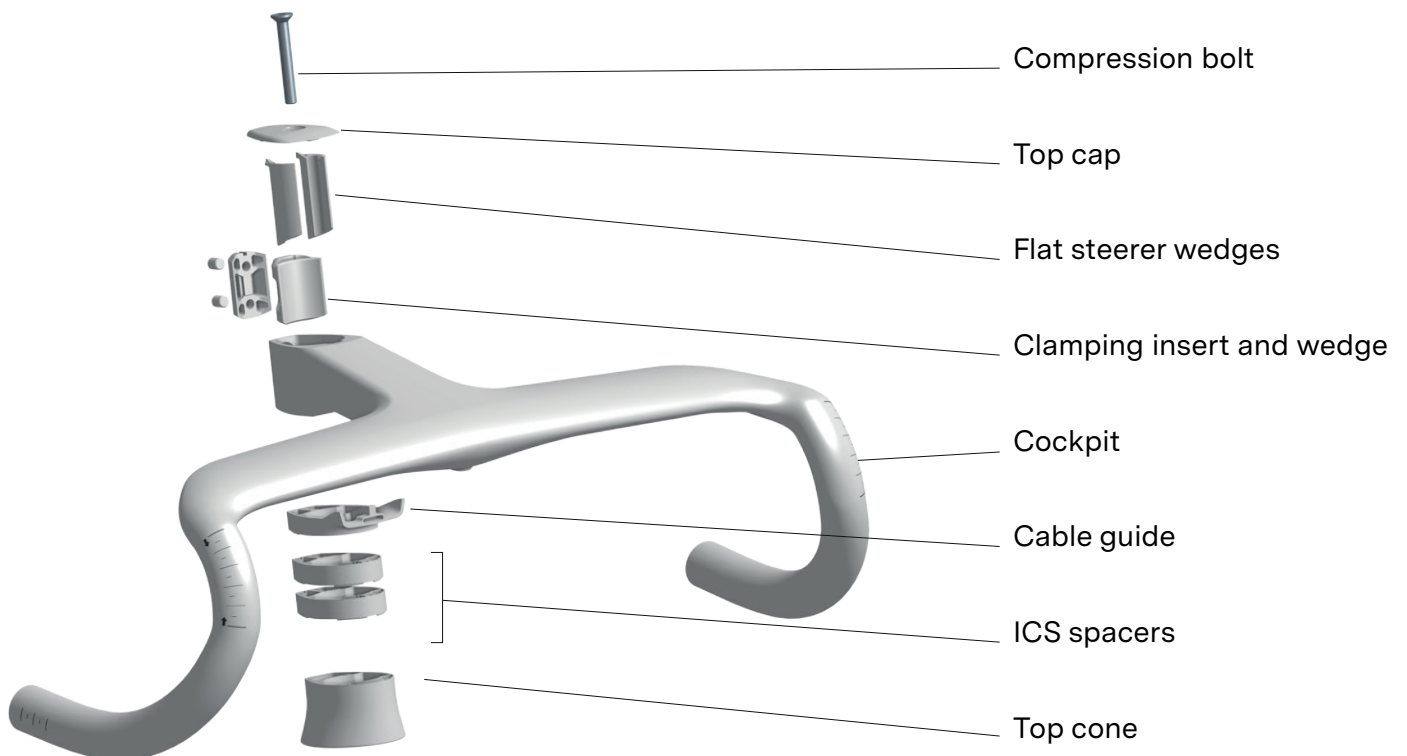

Initial Installation Steps

⚠ WARNING: Follow and respect the installation instructions of your bike. Some assembly details are often specific to the frame design.

1. Install the headset, fork and top cone as instructed by the fork and the frame Owner’s Manual.
2. Clean and degrease the fork’s steerer tube at the area where the cockpit will be clamped.
3. Clean and degrease cockpit areas that interface with the steerer tube.
4. Install the frame top cone and the desired spacer count to match your desired stack.
5. Route front and rear brake hoses through the stem cover (cable guide).
6. Install the cockpit with clamping wedges.
7. Lightly tighten the clamp.

Top Cone Configurations and Selection

1. Select the configuration that best suits your needs: flush top cap, open top cap, or open top cap with an integrated computer mount.
2. Install the top cap of your choice (standard or open).



Flush top cap



Open top cap

ⓘ INFORMATION: The top cone and the additional spacer required for the 'open top cap' configuration are not included with the aftermarket cockpit

Installing Cables, Covers, and Bar Tape

- Place brake hose in grooves



1. Route the brake hoses from the stem to each brake lever.
2. Connect the hoses to the brake levers and bleed your brakes as instructed by the manufacturer.
3. Clean the handlebar and hoses with water and soap to remove any brake fluid. Dry with isopropyl alcohol and a clean cloth.
4. Clamp the brake hose with the cable clamp and tighten the M5x16 bolt to 3 Nm using a hex 3mm.

- Threadlocker

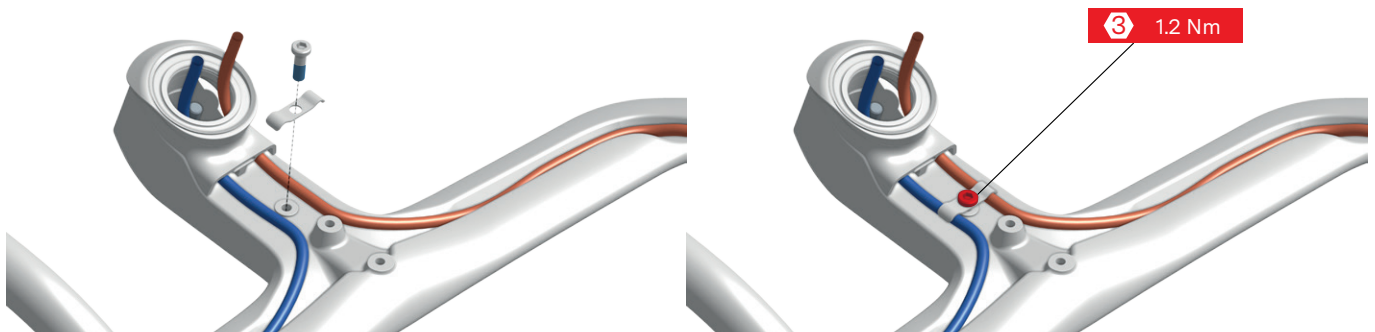

5. Clip cable cover and groove covers, and fix them to the cockpit by tightening the two M5x16 bolts to 3 Nm using a hex 3mm.

- Clip cable cover and groove covers
- Threadlocker

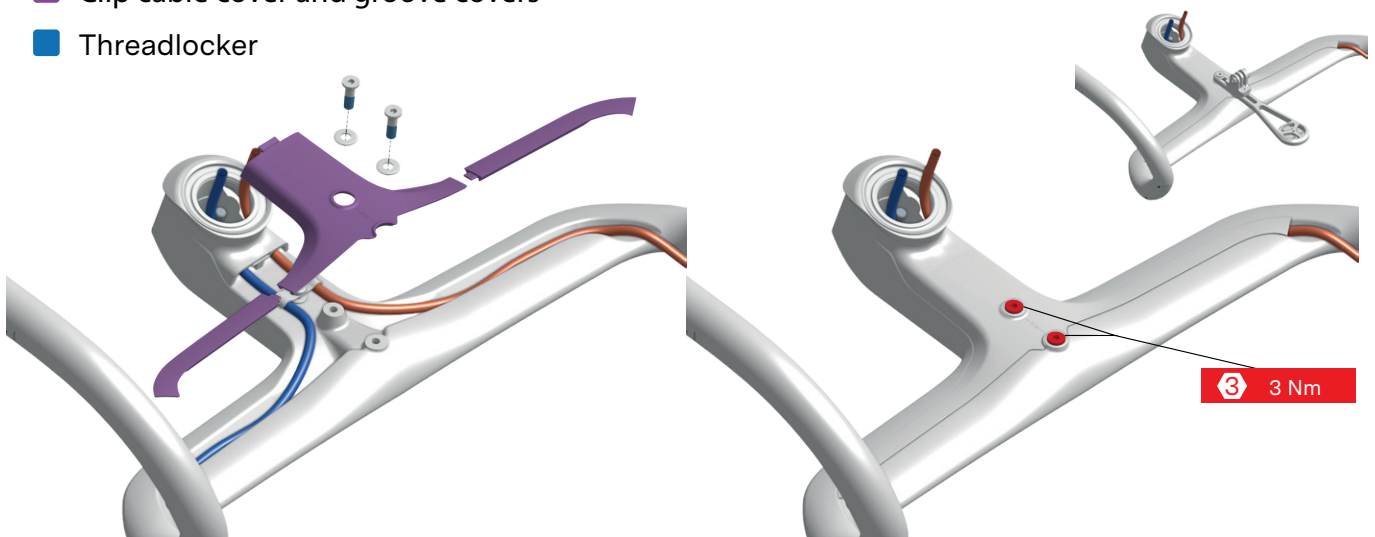

6. Hold the end of each groove cover with electrical adhesive tape.
7. Wrap your favorite bar tape onto your handlebar.

- Electrical adhesive tape

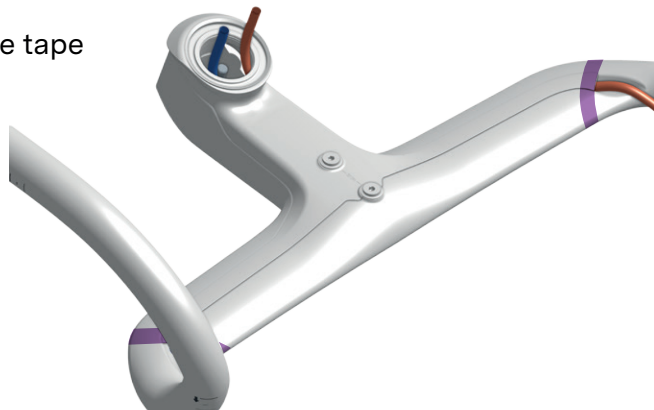

Installing Computer Mount and GoPro Mount

⚠ WARNING: The BMC ICS Carbon Aero Cockpit is designed to accommodate most cycling computers and GoPro-style mounted accessories. However, due to the wide variety of products available, full compatibility with all third-party components cannot be guaranteed.

Always adhere to the specified maximum weight limit and ensure that any mounted accessory is securely and properly installed.

Failure to follow these guidelines may result in the loss of your device, potential damage to your equipment, loss of control, or injury.

	ICS Stems
Computer only max weight	220g
GoPro only load max weight	200g
Total computer and GoPro max weight	300g

1. Choose the adapter compatible with your computer.



Garmin



Wahoo

2. Install the adapter to the computer mount and tighten the adapter bolt to 2 Nm using a hex 2mm.
3. Install the computer mount to the open top cap.

■ Threadlocker

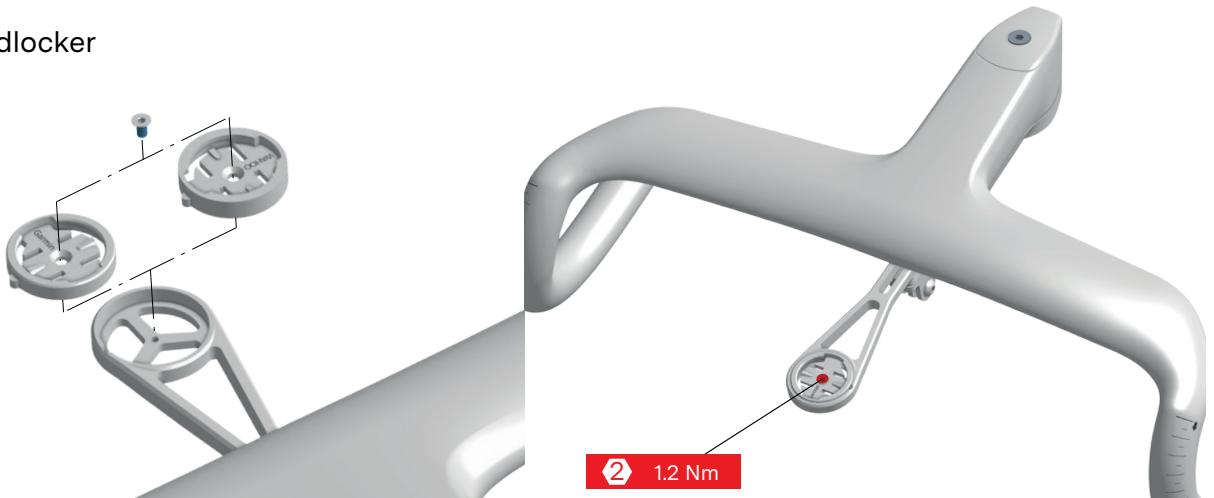

Headset Compression and Clamping the Cockpit

1. Grease, install and tighten the compression bolt to 4Nm using a hex 5mm.
2. Refine the handlebar-wheel alignment using the slight rotational freedom provided by the ICS system.
3. Grease, and tighten the clamp bolts to 5 Nm using a hex 3mm.

⚠ WARNING: Correct headset preload is crucial for a safe, play-free steering system.

⚠ WARNING: Ensure bolts are greased to allow proper clamping force at the specified torque.

■ Grease



Service Instructions

The BMC ICS Carbon Aero Cockpit is a high-tech, performance oriented product. We ask you to take care of your component if you want it to deliver its maximum performance over the years. If you notice wear or damaged, do not hesitate to replace the component and or contact your BMC dealer.

Maintenance

Your cockpit does not require special maintenance outside of regular inspections.

Regularly clean your cockpit with water and a soft cloth. Use water and dish soap. Do not use harsh detergents such as solvents and other similar substances that may damage the clear coat or structural resin of your carbon cockpit. While cleaning, inspect your cockpit and stem for cracks, scratches, deformations or discoloration.

We recommend you to remove your bar tape on a regular basis so you could inspect the cockpit on its entirety.

⚠ WARNING: Regularly inspect your cockpit for any crack, scratch, deformation and discoloration, especially after a crash or impact. No matter how strong the impact was. Regular riding stress, impacts or crash may have a negative effect on the cockpit structure and fragilize it. This could result in failure, which can cause loss of control and a fall. If you have any doubt, replace your cockpit.

⚠ WARNING: The cockpit is designed to be used in corrosive environments, including sweat, salt-water or de-icing salt. The highly corrosive nature of salt requires frequent cleaning and inspections.

Trouble Shooting

Loose brake lever or shifter or grips:

- Clean and degrease the cockpit clamping areas and the components clamping surfaces. Remove any grease or residue.
- Apply grease on the brake lever clamping screw.
- Torque the component's clamp bolt to torque as instructed by the manufacturer.

Noise between cockpit and steerer tube:

- Clean and degrease the cockpit clamping surfaces, the clamp itself, and the fork steerer tube where the cockpit clamps. Remove any grease residue.

Steering system play:

- Do not ride with play in your steering assembly.
- Clean and degrease the connection surfaces between cockpit and fork steerer. Remove any grease residue.
- Apply grease on the clamping bolts as recommended by this manual.
- Torque the bolts to torque as instructed by this manual.

BMC