

Create Speed.

**Kaius**

**01**

Generation 2  
OWNER'S

MANUAL

**BMC**

**Create Speed.**

***BMC***



# Table of content

<b>Introduction</b>	<b>5</b>
<b>Generalities</b>	<b>5</b>
General Notes And Warnings	5
Intended Use	6
Bike registration and warranty extension	6
General notes about this manual	6
Before we start	6
Component Compatibility	7
Special Parts Details	8
General Notes About Assembly	19
Repair Stand	19
Torque Specifications	20
Recommended Assembly Procedure	22
<b>Geometry and Sizing</b>	<b>23</b>
Positioning	23
Frame Geometry	24
<b>Detailed Assembly Instructions</b>	<b>25</b>
Seatpost Assembly	25
Frame Preparation	28
Fork, Headset and Cockpit Preparation	31
Definition of Steerer Tube Length	34
Brake Calipers Assembly	39
Headset, Top Cone and Spacers Assembly	45
Cockpit or Stem Installation	47
Headset Compression and Clamping the Stem	48
Bottom Bracket and Crankset Assembly	49
Bottle Cages	53
Cargo Mounts and Top Tube Plate	54
Wheels and Axles	56
Fenders	58
<b>Service Instructions</b>	<b>59</b>
Washing Your Bike	59
After Washing	59
Trouble Shooting	60
<b>Notes</b>	<b>61</b>



**BMC**



# Introduction

The Kaius series represents the pinnacle of functional integration, and rider-focused fit. By patiently following these guidelines, the content of this manual will lead to properly fitting and functioning equipment with a high-performance, Swiss Engineered aesthetic.

BMC Kaius frame series and components are designed as a system to provide the highest performance level. The frameset combines the latest innovations, and high-end technologies that can be found in bicycle manufacturing, including thin-walled carbon fiber composite construction, which should be treated with care by the end user to prevent permanent and sometimes invisible damage.

For the reasons mentioned above, we ask you to carefully follow the instructions provided in this manual.

Incorrect mechanical operation on your bicycle could lead to serious damage, which could cause you to fall and lead to injury or death.

If you do not have the appropriate tools or experience to execute the following instructions, or if you need further information, please contact your official BMC dealer for service of your bicycle.

---

## Generalities

### General Notes And Warnings

You must read and understand the *Safety Instructions* described in the *BMC Owner's Manual* included with your product before proceeding with installation. Improperly installed components are extremely dangerous and could result in severe and/or fatal injuries. If you have any questions about the installation of these components, consult a qualified bicycle mechanic.

 **WARNING:** Indicates a dangerous or hazardous situation. Not respecting the instruction could result in losing control of the bike or having a component fail. Consequences could be: product damage, injury or death.

 **INFORMATION:** Indicates important information.

This manual uses icons and color codes to indicate actions for proper assembly and adjustments.



Grease



Thread locker



Friction Paste



Torque



Adjust



Measure

## Intended Use

The Kaius series is designed and tested for Gravel riding.

It complies with Level 2 ASTM Classification.

Please read and refer to the general BMC Owner's Manual for more details.

The structural weight limit for the Kaius is 120kg / 264lbs.

**⚠ WARNING:** Always make sure to never exceed the structural weight limit with the sum of rider weight, rider's equipment (e.g., helmet, shoes, apparel) and nutrition (e.g., water, energy gels and bars). Exceeding the structural weight limit may impair the structural integrity of the bike and result in component damage or failure.

## Bike registration and warranty extension

BMC provides a voluntary warranty on the frame, and on BMC components and paintwork. By registering your Kaius within the first six months after initial purchase on the Bike Registration page ([www.bmc-switzerland.com/pages/bike-registration](http://www.bmc-switzerland.com/pages/bike-registration)), you can extend the warranty on the frame to five years.

You can read the warranty provisions in detail on the Warranty policy page ([www.bmc-switzerland.com/warranty](http://www.bmc-switzerland.com/warranty)).

Keep this information in a safe place for future reference:

Date of purchase: ..... Place of purchase: .....  
Model Year: ..... Model Name: ..... Size: .....  
Reference - SKU:  
*printed on the carton box* ..... Serial Number: .....

## General notes about this manual

Read and keep this manual for your BMC Kaius Gen 2. It includes essential safety, performance, and technical details. Refer to it before your first ride and store it in a handy place.

This document is specific to the Kaius Gen 2 and should be read with the "BMC Operating manual".

## Before we start

A Kaius frameset or complete bike includes proprietary components such as seatpost, headset, thru-axles, stem ... For each of those components, you will find part numbers, service and assembly instructions detailed in the following chapters of this manual.



# Component Compatibility

## Brakes:

- Front: flat mount for 160mm rotor only using BMC Teammachine R specific front brake adapter.
- Rear: flat mount brakes 25mm thickness, compatible with Ø160mm rotor

For more details, please refer to “Fork, Headset and Cockpit Preparation”, page 31.

## Headset bearings:

- BMC by FSA, HS-B-13P - standard
- BMC by FSA, HS-B-27P - stainless
- BMC by Ceramic Speed, Headset TM R Mpc - ceramic

For more details, please refer to “Headset Assembly”, page 45.

## Thru-axles:

- Front: BMC model CTS1135, 12x100mm, L115mm, M12 P1.0
- Rear: BMC model CTS0891, 12x142mm, L167mm, M12 P1.0

For more details, please refer to “Wheels and Axles”, page 56.

## Shifting compatibility:

**Chainline:** Designed for gravel chainlines of 47.5mm minimum.

### Electronic groupsets

- Compatible with Shimano 12s Di2 (GRX 1x), Sram AXS, Campagnolo Wireless.
- Not Compatible with Shimano 12s Di2 with wired battery.
- Not compatible with Campagnolo EPS.

### Mechanical shifting groupsets

- Not compatible

## Crankset and chainrings:

- Threaded bottom bracket T47 85.5mm Road Wide (internal bearings).
- Cranksets 1x (single chainring) only
  - Maximum 50t. Minimum 32t.
  - Crank length: 175mm maximum.
  - Q-factor 150mm minimum.

For more details, please refer to “Bottom Bracket and Crankset Assembly”, page 49.

## Tires:

- Min 700x32c.
- Max 700x52c: up to 52mm measured (+6mm clearance around the tire).

## Rack & Fenders:

- No rack is compatible with the Kaius.
- Some fenders with light fastening systems can be fitted onto the Kaius (SKS Speedrocker or RaceB-lades).

## Seatpost:

- Only compatible with BMC SP AS10 proprietary seatpost shape.
- Not compatible with dropper post.

# Special Parts Details

## Kaius 01 - Frameset and Parts

**ⓘ INFORMATION:** The Kaius 01 features Full Mount design rear dropouts and is compatible with UDH hangers or hanger-less derailleurs.

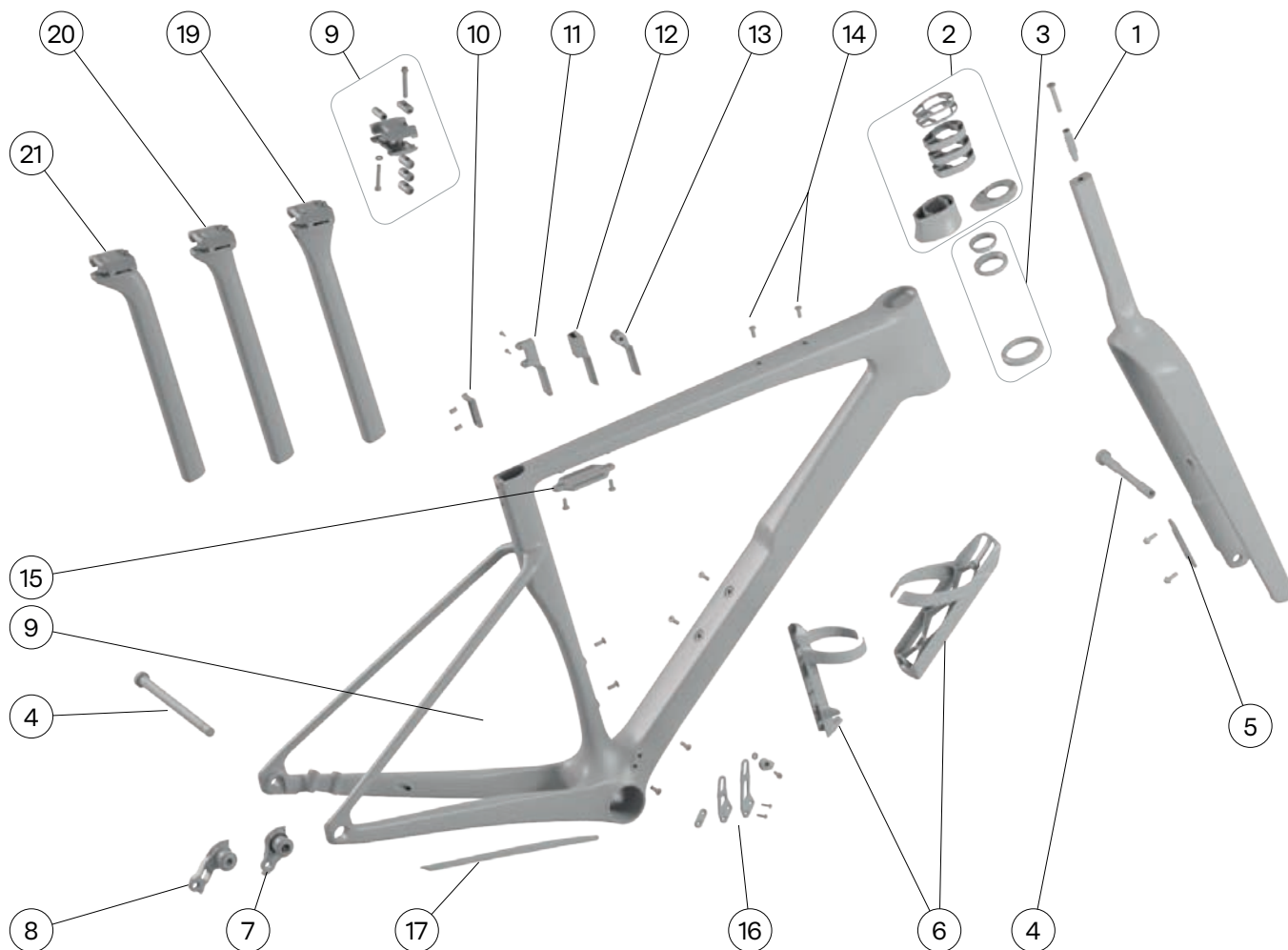



## NO. Description/Details

1	30007222	Flat Steerer Expander Bolt, Short, Incl. Top Cap Bolt
2	30001801	Topcone Set ICS2 ICS Carbon
3	30000704	Headset B 13
3	30007215	Headset Teammachine R Mpc
3	30007614	Headset B 27 Stainless
4	30008531	Axle Kit - No 16
5	30006286	Brake Mount Adapter
6	30006281	Bottle Cage Set
7	N/A	SRAM Universal Derailleur Hanger
8	30008520	Dropout Hanger - No 86
9	30007613	Saddle Clamp No. 6 (Titanium Bolts)
10	30007619	Seatpost Clamp No. 37 (AeroShape Seatpost No. 10)
11	30007618	Number Plate Holder No. 2 (AeroShape Seatpost No. 10)
12	30008350	Rear Light Holder No 1 for SP AS10 for BMC Rear Light
13	30008351	Rear Light Holder No 2 for SP AS10 for GoPro Mount
14	30004028	Top Tube Accessory Mount Plugs
15	30008569	Top Tube Plate incl. Bolts
16	30008570	Chain Guide - No 3 short for 38-42 T chainrings
16	30008571	Chain Guide - No 4 long for 44-50 T chainrings
17	30008572	Chain Stay Protector - No 24
18	30008644	Kaius 01 Gen2 Frame Protection
19	30007855	AeroShape Seatpost No. 10, 0mm offset, 405mm length
20	30007611	AeroShape Seatpost No. 10, 10mm offset, 405mm length
21	30007612	AeroShape Seatpost No. 10, 25mm offset, 405mm length



**BMC**



## Frame Hardware

### Fork Expander



**Article number:**

30007222 FSTR expander bolt, short Flat Steerer Expander Bolt, Incl. Top Cap Bolt

### Top Cones and Spacers Set



**Article number:**

30001801 TC Set ICS2, ICS CBN BLK SLR01 - Topcone Set ICS2 ICS Carbon

### Headset Bearings Set



**Article number:**

- 30000704 HS-B-13-P Standard headset bearings
- 30007614 HS-B-27-P Stainless headset bearings
- 30007215 Headset Teammachine R Mpc - Ceramic Speed headset bearings

### Thru-axles



**Article number:**

30008531 Axle Kit - No 16 (12x100mm + 12x142mm), Front and rear thru-axle kit

## Front Brake Adapter



**Article number:**

30006286 Brake Mount Adapter Front brake  
caliper adapter

## Bottle Cages Set



**Article number:**

30006281 Aero Shape Bottle Cage Set (WBC AS  
No. 3)

includes 4x extra low head screws  
M5x12

## Hangers



**Article number:**

N/A SRAM UDH (available at SRAM)

**Article number:**

30008520 Dropout Hanger - No 86 (Shimano Di-  
rect Mount for Full Mount frames)

## Saddle Clamp



**Article number:**

30007613 Saddle Clamp No. 6 (Titanium Bolts)



## Seatpost Clamp



**Article number:**

30007619 Seatpost Clamp No. 37 (AeroShape No. 10 Seatpost)

**Article number:**

30007618 Number Plate Holder No. 2 (AeroShape Seatpost No. 10)

**Article number:**

30008350 Rear Light Holder No. 1 for SP AS10 and BMC Rear Light

**Article number:**

30008351 Rear Light Holder No. 2 for SP AS10 and GoPro Mount

---

## Cargo Mounts Parts



**Article number:**

30004028 Top Tube Accessory Mount Plugs

30008569 Top Tube Plate incl. Bolts

## Chain Guides and Protectors



### Article number:

30008570 Chain Guide - No 3, short for 38-42 T chainrings

30008571 Chain Guide - No 4, long for 44-50 T chainrings

### Article number:

30008572 Chain Stay Protector - No 24

### Article number:

30008644 Kaius 01 Gen2 Frame Protection



## Stems & Cockpit

The Kaius frameset is only compatible with ICS type cockpits and stem for internal brake cable routing.

	Kaius (flat steerer fork)
ICS 2.0 standard integrated cables	✓
ICS 1.0 standard integrated cables	✓
1"1/8 stems external cables	✗

First generation ICS stems "ICS1.0" is also compatible with Kaius. However, you will need to replace the top cone and spacers to ICS1.0 versions.

### Computer Mount for stems



**Article number:**

30000718 COM ICS1 ICS2 Computer Mount | ICS, ICS2, ICS MTT and RSM01 Stems

### ICS 2 Stem



**Article number:**

- 30001784 ST ICS2 80mm
- 30001785 ST ICS2 90mm
- 30001786 ST ICS2 100mm
- 30001787 ST ICS2 110mm
- 30001788 ST ICS2 120mm
- 30001789 ST ICS2 130mm
- 30001790 ST ICS2 140mm
- 30000718 COM ICS1 ICS2 Computer Mount | ICS, ICS2, ICS MTT and RSM01 Stems

### RSM01 Stem



**Article number:**

- 30007807 ST RSM01, 70 mm
- 30007808 ST RSM01, 80 mm
- 30002072 ST RSM01, 90mm
- 30002073 ST RSM01, 100mm
- 30002074 ST RSM01, 110mm
- 30002075 ST RSM01, 120mm
- 30007594 RSM01 ICS Kit - Cable Guide And Rear Cover

## Cockpit ICS2 Carbon Aero Gen 2



### Article number:

#### Cockpit ICS Carbon Aero Mpc.

- 30007862 CKP ICS2 CBN AERO Mpc. 90 370/420 BLK
- 30007863 CKP ICS2 CBN AERO Mpc. 100 370/420 BLK
- 30007864 CKP ICS2 CBN AERO Mpc. 110 370/420 BLK
- 30007865 CKP ICS2 CBN AERO Mpc. 120 370/420 BLK

#### Cockpit ICS Carbon Aero Gen2

- 30007867 CKP ICS2 CBN AERO GEN2 80 370/420 BLK
- 30007868 CKP ICS2 CBN AERO GEN2 90 370/420 BLK
- 30007869 CKP ICS2 CBN AERO GEN2 100 370/420 BLK
- 30007870 CKP ICS2 CBN AERO GEN2 110 370/420 BLK
- 30007871 CKP ICS2 CBN AERO GEN2 120 370/420 BLK
- 30007872 CKP ICS2 CBN AERO GEN2 130 370/420 BLK
- 30007873 CKP ICS2 CBN AERO GEN2 140 370/420 BLK
- 30007874 CKP ICS2 CBN AERO GEN2 90 390/440 BLK
- 30007875 CKP ICS2 CBN AERO GEN2 100 390/440 BLK
- 30007876 CKP ICS2 CBN AERO GEN2 110 390/440 BLK
- 30007877 CKP ICS2 CBN AERO GEN2 120 390/440 BLK
- 30007878 CKP ICS2 CBN AERO GEN2 100 410/460 BLK
- 30007879 CKP ICS2 CBN AERO GEN2 110 410/460 BLK
- 30007880 CKP ICS2 CBN AERO GEN2 120 410/460 BLK

## Cockpit ICS2 Carbon EVO



### Article number:

- 30005534 CKP ICS2 CBN EVO 70 400/436 BLK
- 30005535 CKP ICS2 CBN EVO 80 400/436 BLK
- 30005536 CKP ICS2 CBN EVO 90 400/436 BLK
- 30005537 CKP ICS2 CBN EVO 100 400/436 BLK
- 30005538 CKP ICS2 CBN EVO 110 400/436 BLK
- 30005539 CKP ICS2 CBN EVO 120 400/436 BLK
- 30003196 Computer Mount | ICS Carbon and ICS Carbon EVO Cockpits

## Cockpit ICS Carbon Aero



### Article number:

- 30003720 CKP ICS2 CBN AERO 80 360/420 BLACK
- 30003721 CKP ICS2 CBN AERO 90 360/420 BLACK
- 30003722 CKP ICS2 CBN AERO 100 360/420 BLACK
- 30003723 CKP ICS2 CBN AERO 110 360/420 BLACK
- 30003724 CKP ICS2 CBN AERO 120 360/420 BLACK
- 30003725 CKP ICS2 CBN AERO 130 360/420 BLACK
- 30003726 CKP ICS2 CBN AERO 140 360/420 BLACK
- 30003730 Computer Mount | ICS Carbon Aero Cockpit

## Cockpit ICS Carbon



### Article number:

- 30001767 CKP ICS Carbon 90 400 BLACK
- 30001768 CKP ICS Carbon 100 420 BLACK
- 30001769 CKP ICS Carbon 110 420 BLACK
- 30001770 CKP ICS Carbon 120 420 BLACK
- 30003196 Computer Mount | ICS Carbon and ICS Carbon EVO Cockpits



## Seatpost

### Seatpost Options

Depending on the frame size the Kaius is delivered with either “0mm offset” or “10mm offset” seatpost providing an standard range of adjustment for road bike fitting.

Seatpost length is sized according to the frame size:

- 335mm on size 47, 51
- 385mm on size 54, 56
- 405mm on size 58, 61

Optional “0mm offset”, “10mm offset” and “25mm offset” seatposts are available for riders who need a more forward or rearward position or to help deal with some particular saddle rails (carbon saddle rails can push the seating area backwards).

Replacement seatposts are offered in a longer 405 mm option. You may have to cut this version depending on your frame size and saddle height.

Please follow the recommended assembly instructions available in this manual “Seatpost Assembly”, page 25.



25mm offset seatpost  
(optional)



10mm offset seatpost  
(standard)



0mm offset seatpost  
(optional)

**Article number:**

30007855 AeroShape Seatpost No. 10  
SP AS10 1 0-405

offset 0mm  
length 405mm

**Article number:**

30007611 AeroShape Seatpost No. 10  
SP AS10 1 10-405

offset 10mm  
length 405mm

**Article number:**

30007612 AeroShape Seatpost No. 10  
SP AS10 1 25-405

offset 25mm  
length 405mm



**BMC**



# General Notes About Assembly

## Tools

Bike specific tools are required to perform the assembly of your Kaius and its components. We recommend that you have a qualified bicycle mechanic correctly install these components.

Before you start assembling, make sure you are equipped with the following tools:

Standard keys and torque wrench + bits

- Hex / Allen: 2, 2.5, 3, 4, 5, 6 mm

Special tools

- Carbon saw blade Park Tool CSB-1.
- Park Tool IR-1.2 Internal Cable Routing Kit

Grease compounds:

- Grease gun or grease brush
- Fine assembly grease
- Friction paste
- LOCTITE® 243 Blue threadlocker

Operator protection:

- Eye protection
- Hand protection

---

## Repair Stand

 **WARNING:** Clamping the frame or its components into a bike repair stand could damage its structure or finish.

 **WARNING:** Never clamp the frame by the top tube, downtube or seat tube.

Please use a traditional fork mount stand like the Park Tool PRS-22.2 Team Issue Repair Stand.

Alternatively, you can use a standard mechanic's repair stand by clamping the seatpost tube, ensuring you do not damage the tube through excessive clamping force or scratch the clear coat by using unsuitable stand jaws.

# Torque Specifications

**⚠ WARNING:** Respecting and applying the correct torque on fasteners is important for your safety. If too little force is applied the component will not be secure and if too much force is applied the component's thread could deform and break.

Therefore, not respecting the torque specification of any component could result in failure, which can cause loss of control and a fall.

Designation	Specification	Tool	Torque value
Bottle cages & cargo mounts	Hex socket head cap screw low head, M5x12mm	Hex 3mm	3 Nm
Seat post clamp	Hex socket set screws, M6x9mm P0.75	Hex 3mm	3 Nm
Rear derailleur hanger	Full Mount hanger (UDH)	Hex 8mm	↻ 25 Nm
Brake mount adapter	Button head bolt M5x14mm	Hex 4mm	6 Nm
Saddle clamp Nut	M5x24 nut	Hex 6mm	Alignement
Saddle clamp Rear	Hex socket head cap screws, M5x28mm	Hex 4mm	6 Nm
Saddle clamp Front	Special hex socket head cap screws, M6x35mm	Hex 4mm	6 Nm
Headset compression	Hex socket flat countersunk head screw, M6x45mm	Hex 4mm	4 Nm
Chain-guide bracket	Hex socket flat countersunk head screw M3x16mm	Hex 2mm	1 Nm
Chain-guide head	Hex socket head cap screw low head M4x10mm	Hex 3mm	1 Nm
Thru axle Front	BMC model CTS1135 12x100mm, L 115mm, M12 P1.0	Hex 6mm	10 Nm
Thru axle Rear (>MY26)	BMC model CTS0891, 12x142mm, L 167mm, M12 P1.0	Hex 6mm	10 Nm
ICS Carbon Aero Gen2 Cockpit steerer clamp	Hex headless set screw M6x10mm P0.75	Hex 3mm	5 Nm
ICS Carbon Evo Cockpit steerer clamp	Hex socket head cap screws, M4x14mm	Hex 3mm	3 Nm
ICS2 Stem face plate bolts	Hex socket head cap screw, M5x16mm	Hex 4mm	5 Nm
ICS2 Stem steerer clamp bolts	Hex socket head cap screw, M5x16mm	Hex 4mm	5 Nm
RSM01 Stem face plate bolts	Hex socket head cap screw, M5x14.5mm	Hex 4mm	6 Nm
RSM01 Stem steerer clamp bolts	Hex socket head cap screw, M5x14.5mm	Hex 4mm	6 Nm

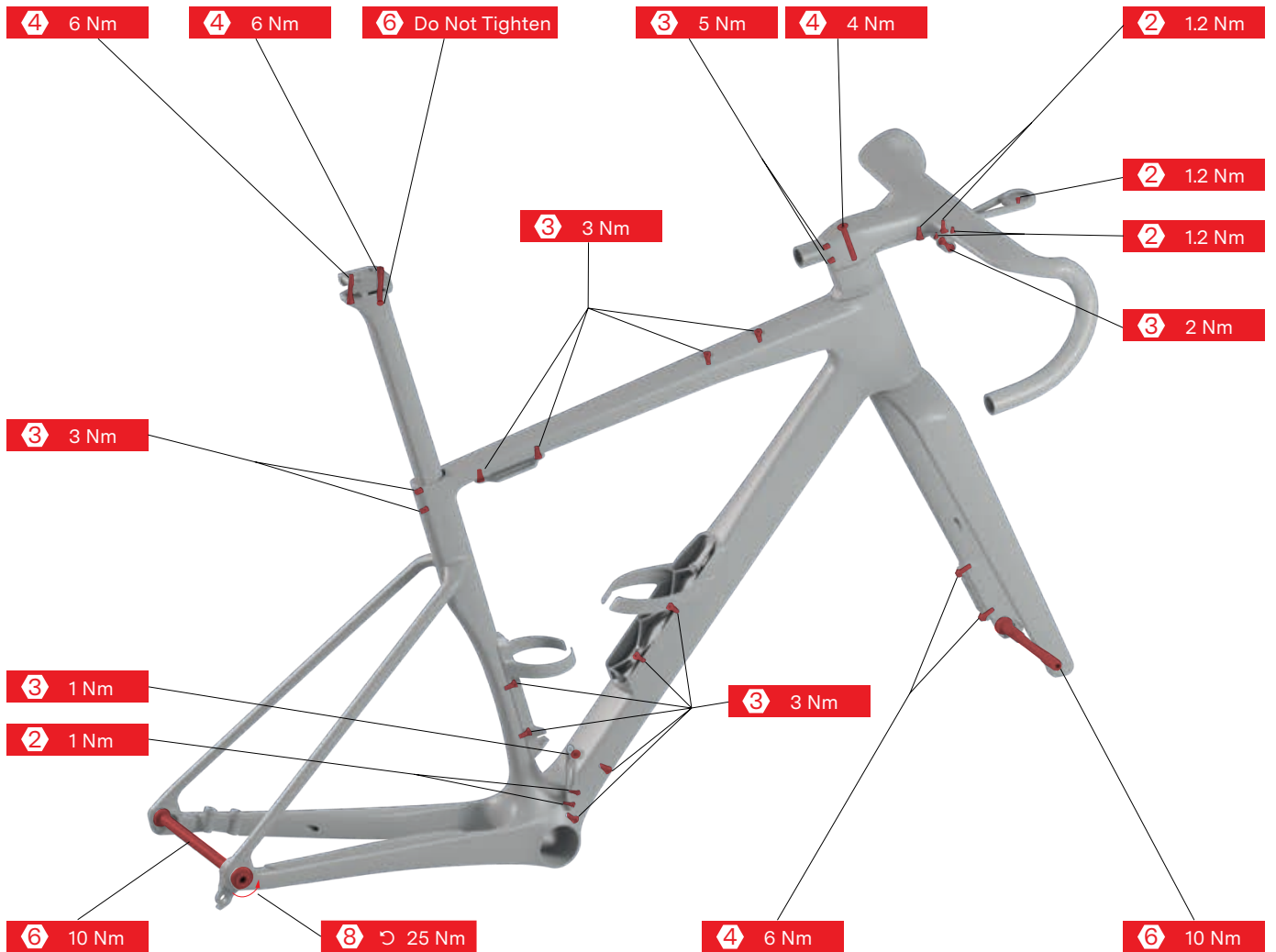
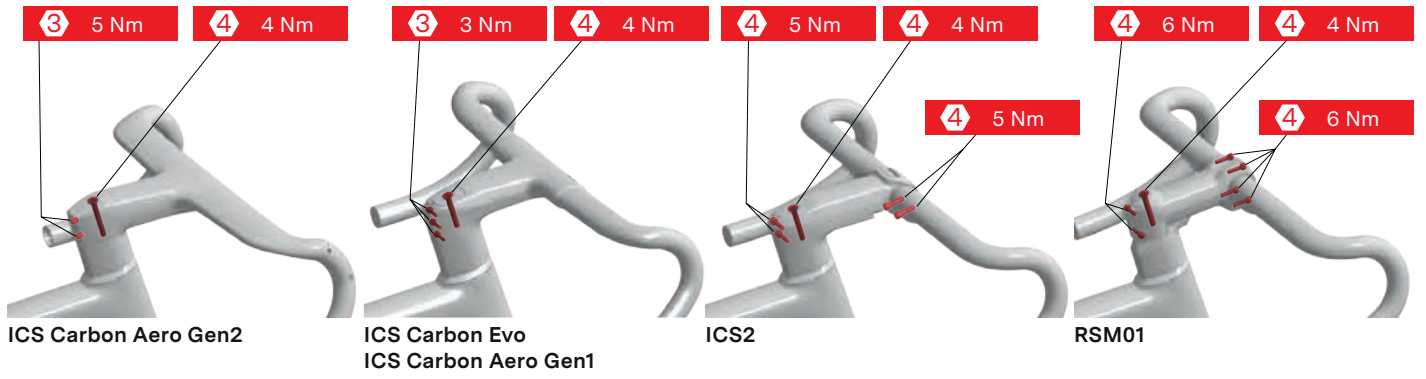

## Recommended Assembly Procedure

If you are building a Kaius from scratch, the most convenient way is to follow the order and the procedure described below. This is only the general procedure, all the separate steps and recommendations are described one by one in the following pages of this manual.

**i** INFORMATION: Please go through all the instructions before starting. Following this sequence will help you save time and facilitate the assembly.

1. Geometry and Sizing
2. Seatpost Assembly
3. Frame Preparation
4. Fork, Headset and Cockpit Preparation
5. Definition of Steerer Tube Length
6. Brake Calipers Assembly
7. Headset, Top Cone and Spacers Assembly
8. Cockpit or Stem Installation
9. Headset Compression and Clamping the Stem
10. Bottom Bracket and Crankset Assembly
11. Bottle Cages
12. Wheels and Axles
13. Fenders



# Geometry and Sizing

## Positioning

A bicycle rider will only perform at their best if they are correctly positioned on their bike. Proper positioning not only enhances your riding experience but also helps prevent strain or injury over time.

To ensure optimal comfort, performance, and safety while riding, we strongly recommend utilizing a professional bike fitting service when ordering or setting up your new bike. A bike fitter can assess your unique body requirements, riding style, and flexibility to fine-tune your bike's adjustments, such as saddle height, saddle position and handlebar position.

If a professional bike fitting is not immediately accessible, take the time to carefully evaluate your bike's setup to ensure it matches your riding needs and personal measurements. If you are transitioning from a previous bike, it is crucial to confirm that your current bike setup is appropriate for your new bike's geometry and specifications.

# Frame Geometry

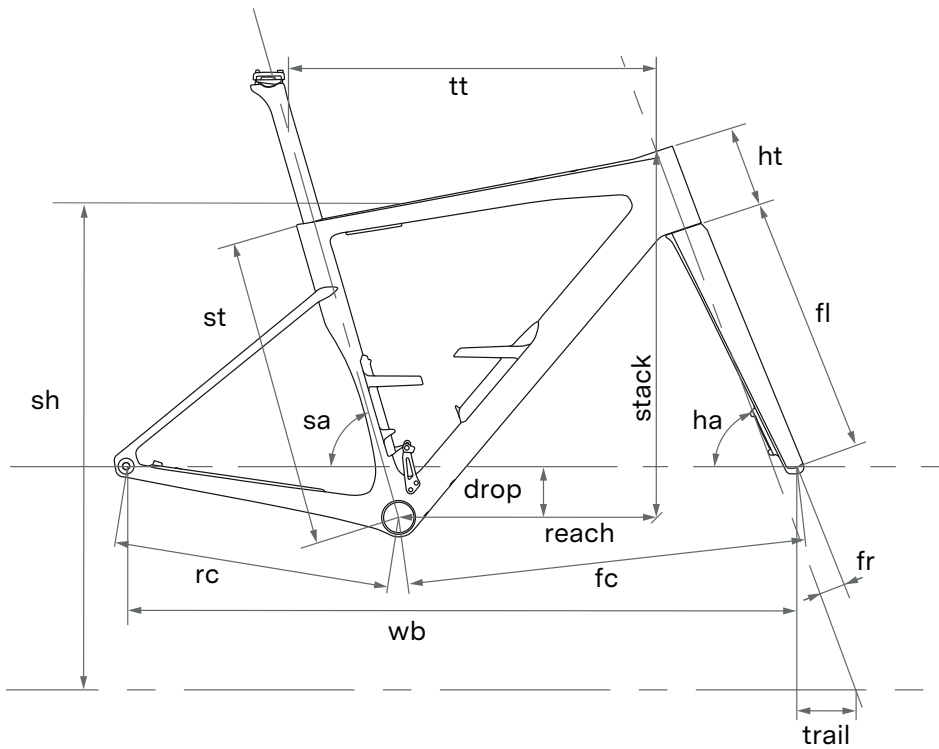

Size	47	51	54	56	58	61
Rider Height cm	<166	166-174	172-180	178-186	184-192	>190
Stack	521	541	561	581	606	631
Reach	385	392	396	400	405	409
Seat Tube (st)	429	449	471	485	509	533
Top Tube (tt')	531	544	559	569	587	598
Head Tube (ht)	88	109	126	147	173	199
Seat Angle ° (sa)	74.3°	74.3°	73.8°	73.8°	73.3°	73.3°
Head Angle ° (ha)	70.8°	70.8°	70.8°	71.6°	71.6°	71.6°
Rear Center (rc)	425	425	425	425	425	425
Front Center (fc)	597	611	614	619	633	645
Wheelbase (wb)	1010	1024	1027	1032	1045	1058
BB drop (drop)	79	79	79	79	79	79
Fork Length (fl)	397	397	397	397	397	397
Fork Rake (fr)	50	50	50	45	45	45
Trail	72	72	72	72	72	72
Standover Height (sh)	739	758	779	795	815	838
Seatpost Length	335	335	385	385	405	405
Seatpost Offset	0	0	10	10	10	10
Seatpost Max Insertion	120	140	170	170	190	210

Optimized for 700x45c tires (45mm measured).



# Detailed Assembly Instructions

## Seatpost Assembly

### Seatpost Length

The three seatposts compatible with the Kaius have a minimum and a maximum insertion depth in the frame.

Size	47	51	54	56	58	61
Seatpost Length	335	335	385	385	405	405
Min insertion	80	80	80	80	80	80
Max insertion	120	140	170	170	190	210

**⚠ WARNING:** Always make sure you are respecting the min insertion length of 80mm.

**ℹ INFORMATION:** If the max insertion is too restricting and does not allow a low enough saddle height, you can cut your seatpost to a shorter length to allow you to reach your ideal saddle height.

**ℹ INFORMATION:** Use a saw guide like the Park Tool SG-7.2 Oversized Adjustable Saw Guide and an appropriate carbon specific saw blade such as the Park Tool CSB-1.

**⚠ WARNING:** If cutting the seatpost, make sure to respect the maximum cutting instruction.

■ Maximum cutting length

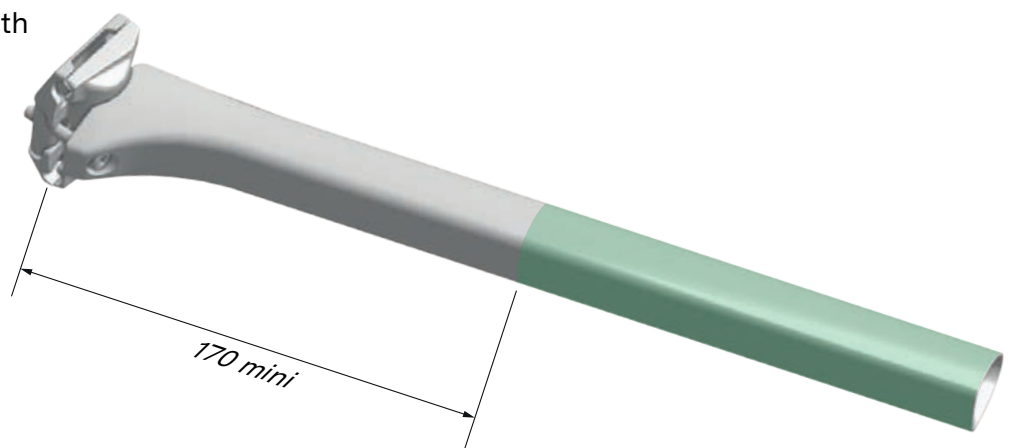

Create Speed.



**BMC**



## Saddle Clamp Installation

1. Pre-install the lower clamp, the upper clamp, the 2 barrel nuts and finally pre-install the M6 (front) and M5 (rear) bolts:
  - 1.1. Special Long M6x35 at the front (no washer).
  - 1.2. Short M5x28 + washer at the rear.
2. Install your saddle by clamping the rails between the 2 clamps and adjust the saddle setback and tilt before clamping both bolts.
3. Tighten the rear M5x28 bolt to 6 Nm using a hex 4mm.

**ⓘ INFORMATION:** The front barrel nut features a 4mm hex head, making it easier to turn and simplifying the installation of the front bolt.

**ⓘ INFORMATION:** The special front bolt design allows you to conveniently adjust your saddle tilt using a 4mm Allen key, a 7mm socket wrench, or a small metal rod ( $\varnothing < 1\text{mm}$ ).

**⚠ WARNING:** Always tighten to the correct torque. Not respecting this recommendation may result in the saddle coming loose, losing control of the bike and falling.

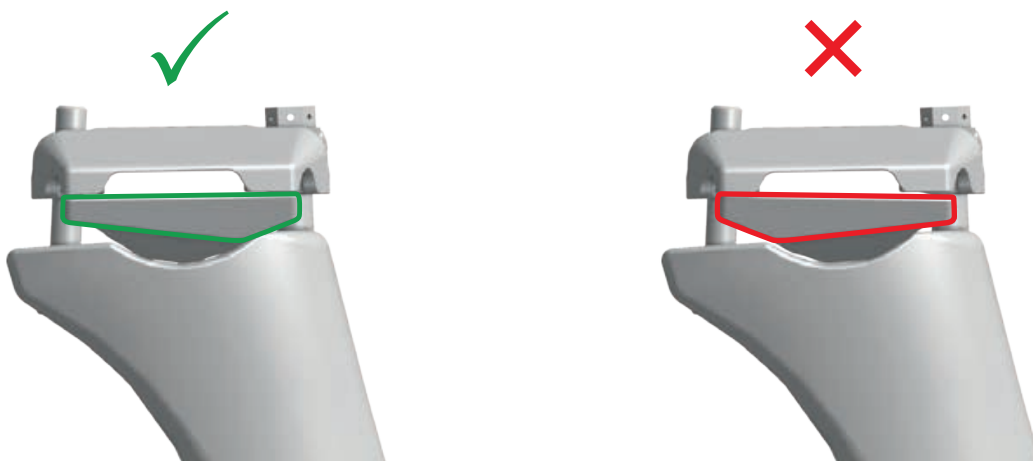
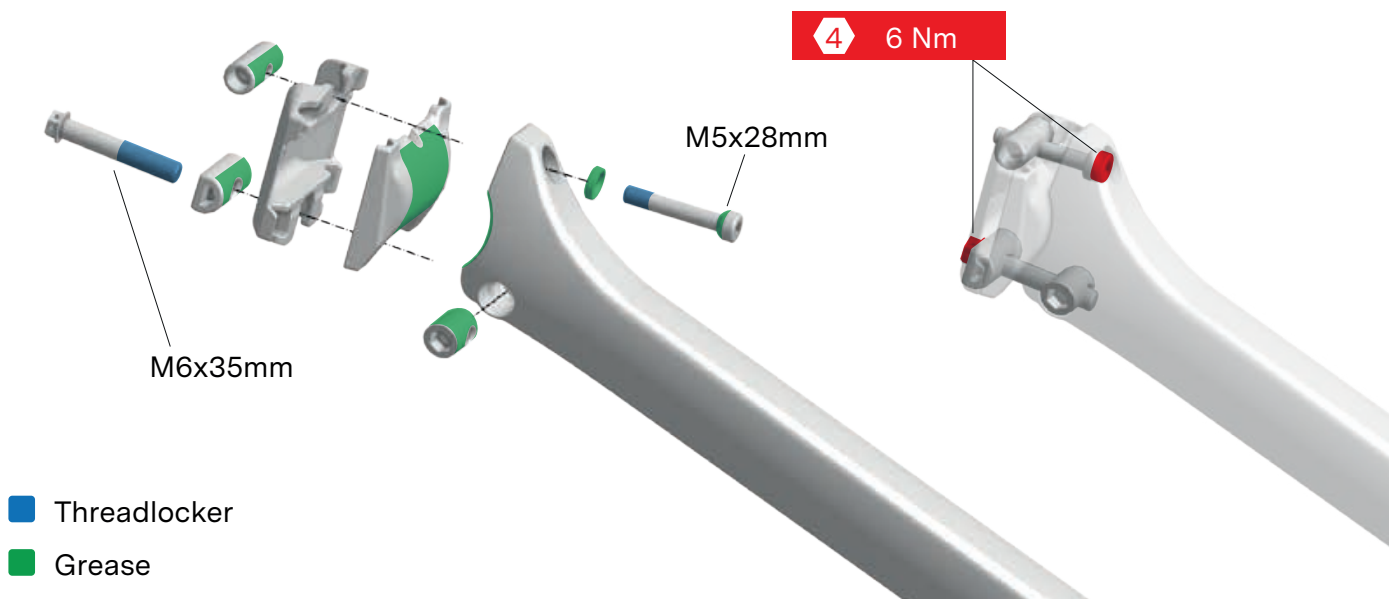

**⚠ WARNING:** Always respect the orientation of the lower clamp as illustrated above.

# Frame Preparation

## Frame Seatpost Clamp Installation

1. Apply a thin layer of friction paste to the seatpost and the inside of the seat tube.
2. Grease the two M6x9 P0.75 set screws and engage them into the frame's threaded inserts.
3. Insert the seat clamp plate into the seat tube; its magnet will hold it in place.
4. Slide the seatpost into the frame and adjust it to your desired saddle height.
5. Tighten the M6x9 P0.75 set screws to 3 Nm using a hex 3mm wrench.

**⚠ WARNING:** Remember to respect the minimum insertion of 80mm. Not respecting the minimum insertion could result in frame or seatpost damage, breakage and injury.





## Rear Derailleur Hanger Installation

### Kaius 01 (full mount design)

- Select the right model of hanger depending on your groupset, and the rear derailleur design. You can choose between
  - No dropout hanger when using a hanger less derailleur.
  - SRAM UDH dropout hanger: for standard derailleurs.
  - Direct mount for Full Mount dropout hanger: usually used with Shimano's or Campagnolo's latest generation of derailleurs.

SRAM UDH

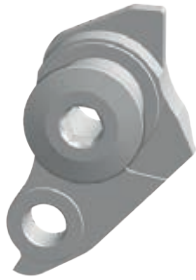

Direct mount for Full Mount

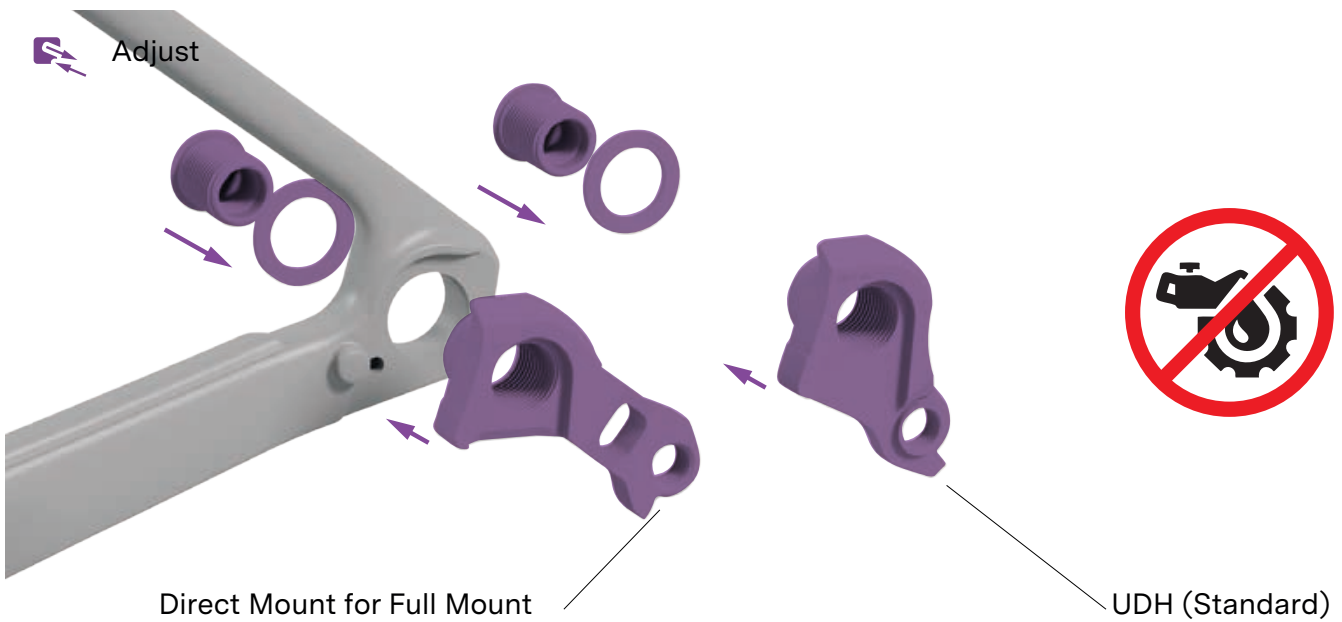

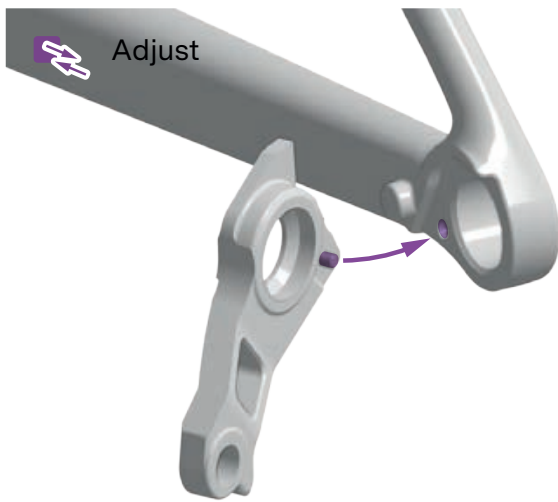

Direct Mount for Full Mount

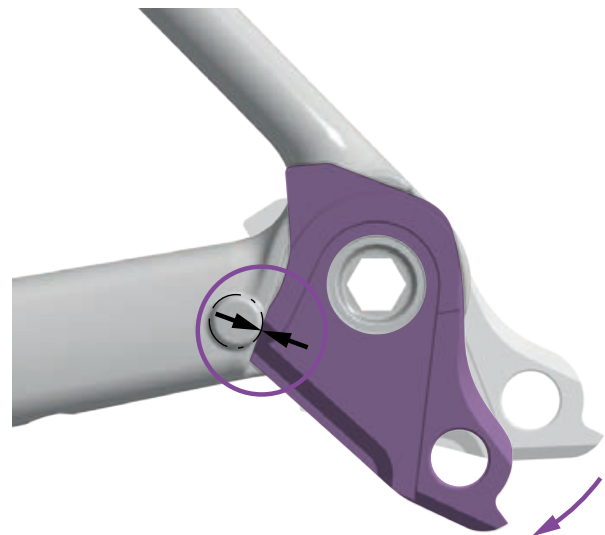

UDH (Standard)

2. Position the selected hanger in the frame dropout:

- **Direct Mount hanger for Full Mount:** align the hanger pin with the frame hole, and install the hanger into the frame dropout.
- **UDH Standard hanger:** Rotate the UDH hanger forward until it is completely seated in the hanger pocket or contacts the rotational stop tab.

 Torque

 25 Nm

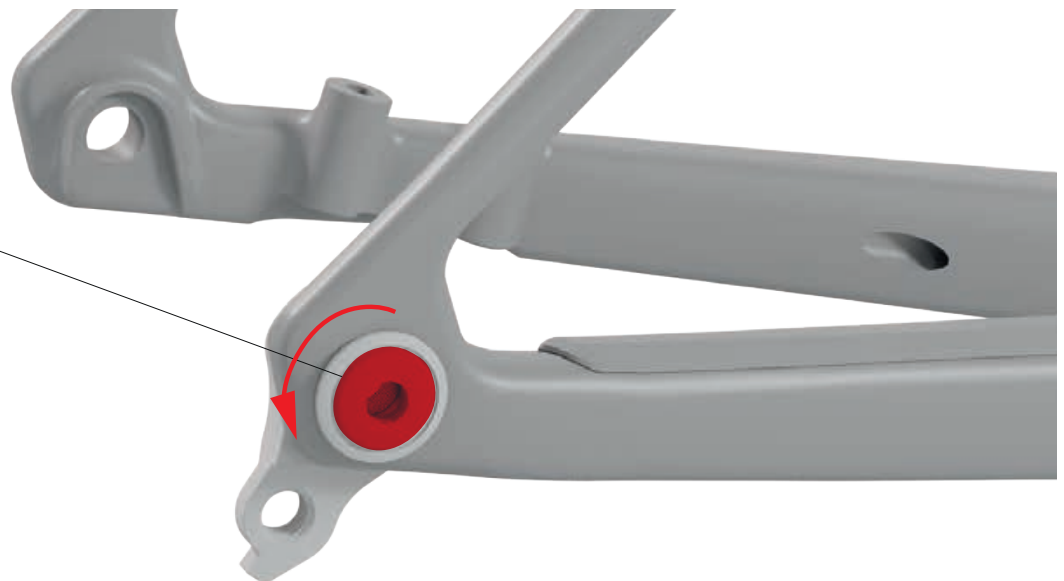

3. Install the frame-specific UDH washer. Install the UDH bolt through the washer and into the UDH hanger threads. Tighten the bolt to the specified torque.
4. Tighten counter-clockwise to 25 Nm.

 **INFORMATION:** The Full mount hanger bolt is left-hand threaded.



# Fork, Headset and Cockpit Preparation

## Cockpits and Stems Parts Selection

1. Refer to the following illustrations to identify each component.

### ICS Carbon Aero Cockpit Gen 1 -and- ICS Carbon Evo Cockpit

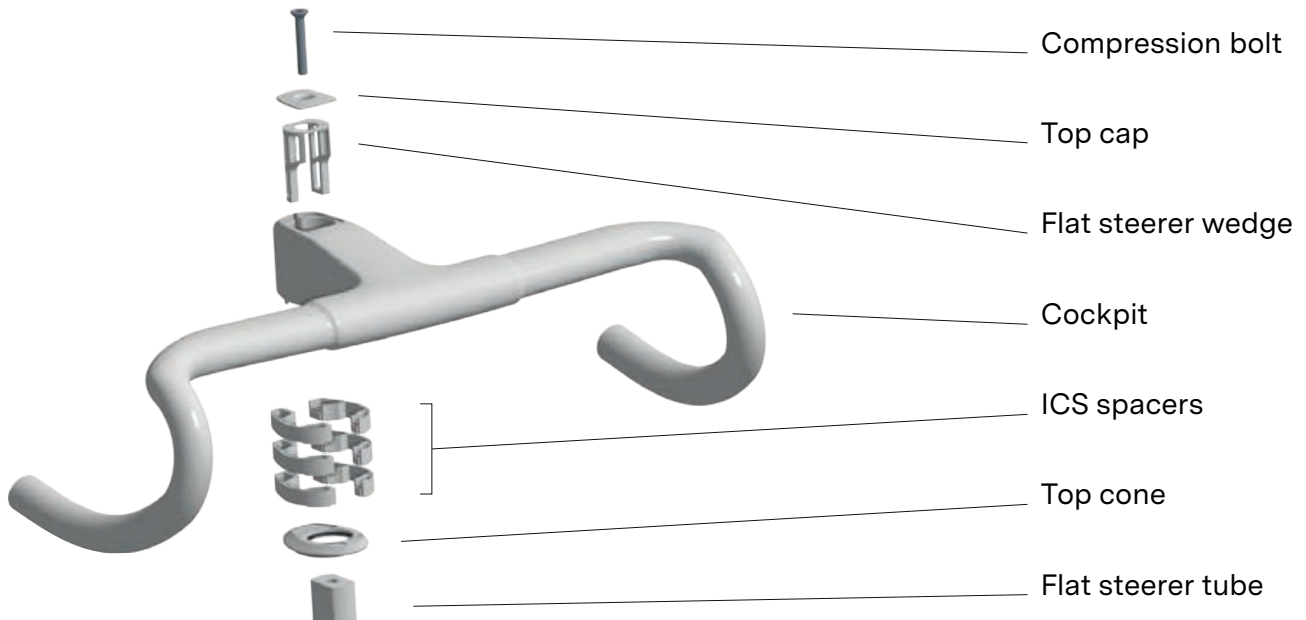

### ICS Carbon Aero Cockpit Gen 2

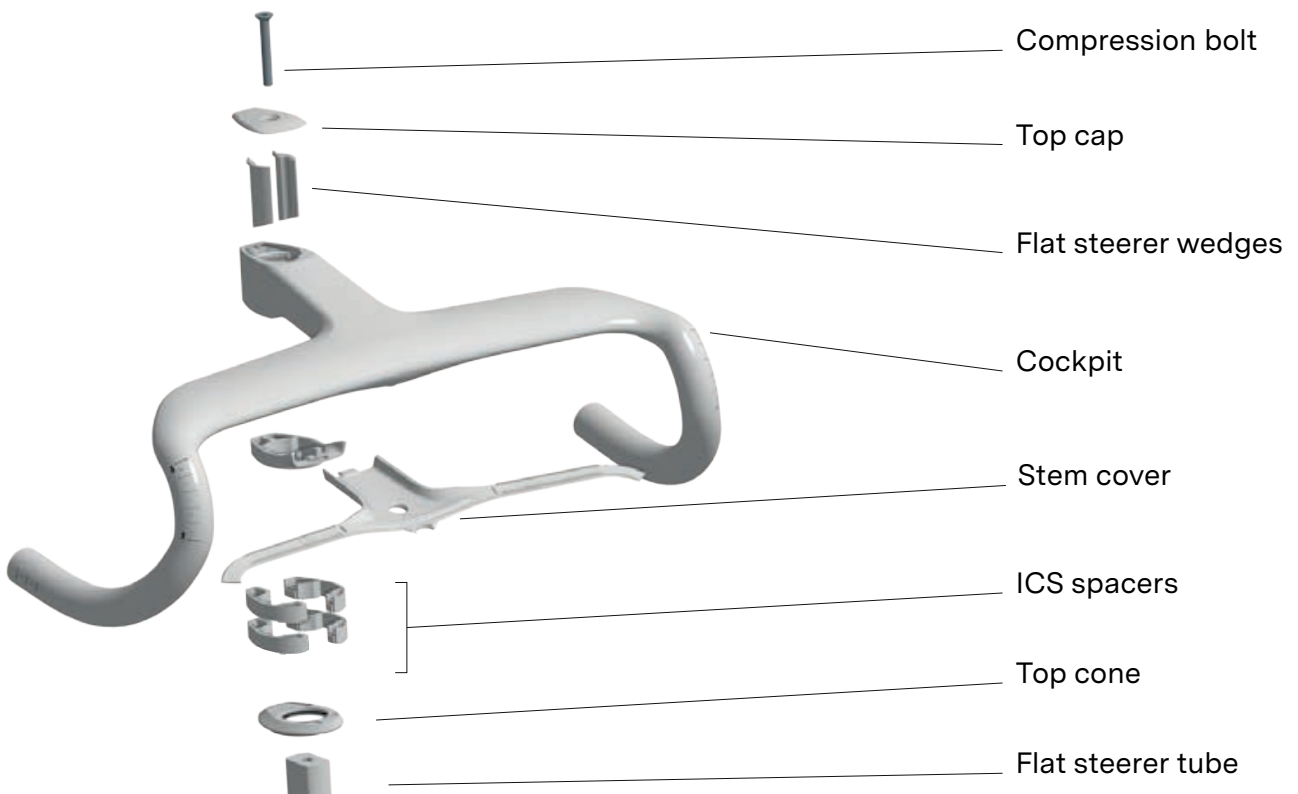

## ICS2 Stem

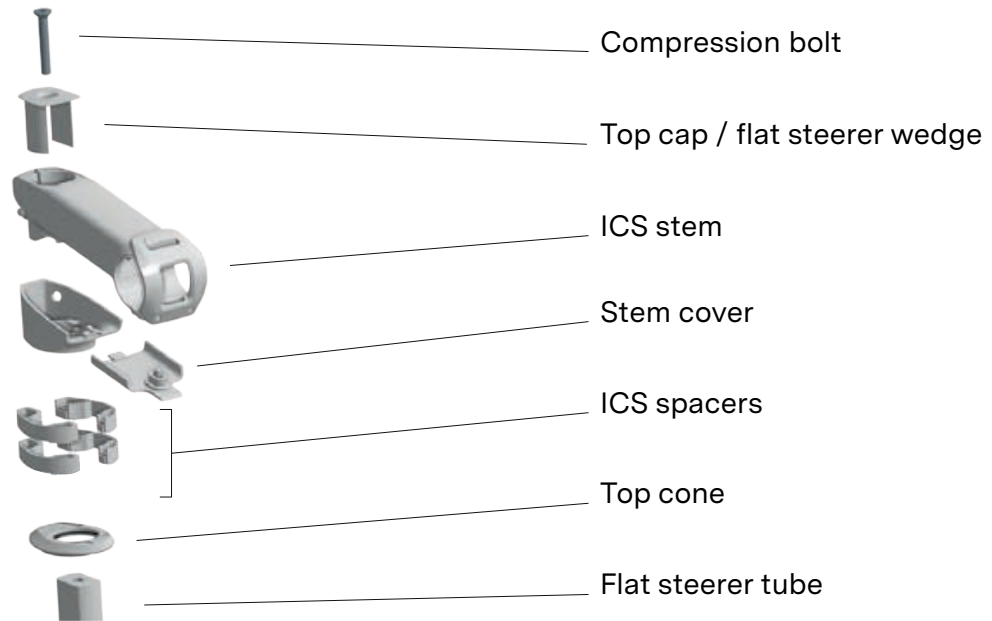

## RSM01 with ICS Core

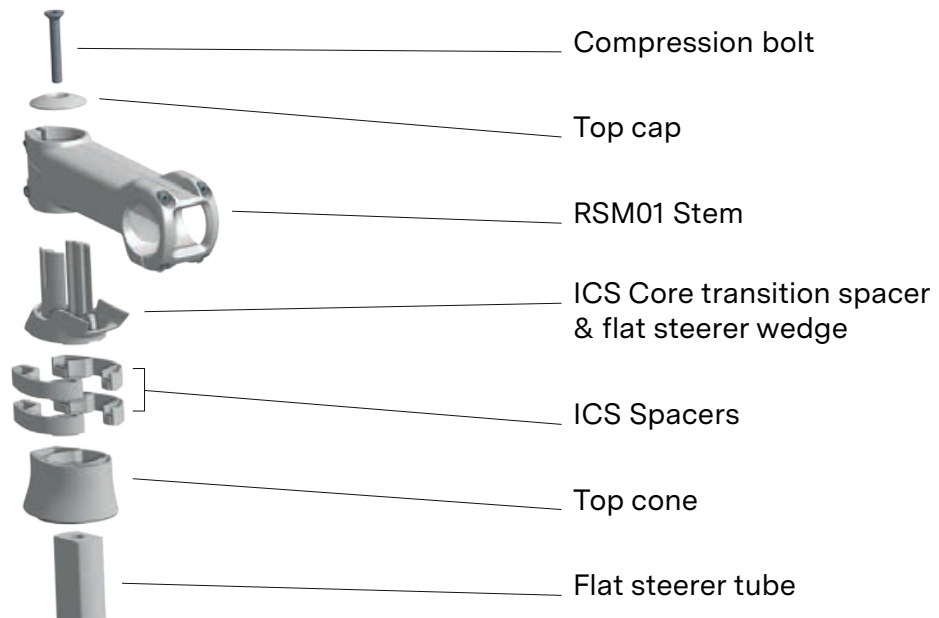



## Minimum and Maximum Spacer Stack

2. Determine the stack height based on the rider’s initial or desired position.

**⚠ WARNING:** do not exceed the spacer height and spacer count. Failure to follow these recommendations may result in steering issues resulting in losing control of the bike and a potential crash.

	ICS Carbon Aero Cockpit Gen 1 -and- ICS Carbon Evo Cockpit		ICS Carbon Aero Cockpit Gen 2 -and- ICS Stems	
<b>Top cone</b>	#1 Low [or] #2 High		#1 Low [or] #2 High	
<b>Spacer type</b>	ICS		ICS	
<b>Spacer max quantity</b>	3		2	
<b>Stack options</b>	Lowest	Highest	Lowest	Highest
<b>Stack height</b>	5mm	60mm	15mm	60mm
<b>Stem cover</b>			10mm	10mm
<b>Spacers</b>		3x 10mm		2x 10mm
<b>Top cone</b>	#1 Low (5mm)	#2 High (30mm)	#1 Low (5mm)	#2 High (30mm)



## Definition of Steerer Tube Length

**⚠ WARNING:** The steerer tube must be cut to the correct length to avoid malfunction.

3. Install the headset components to determine the cutting length of the steerer tube:
  - 3.1. Fork
  - 3.2. Lower bearing
  - 3.3. Upper bearing
  - 3.4. Compression ring
  - 3.5. Top cone (high or low)
  - 3.6. Spacers
  - 3.7. Stem cover and stem body [or] cockpit
4. Clip the right and left sides of each spacer by sliding them into place on top of one another.

 Align and clip

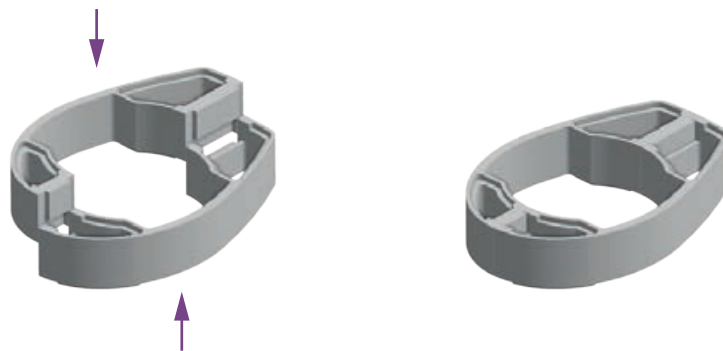

5. Align the different elements to achieve the desired stack.

 Pre-assemble all components



6. Gently compress the system together and tighten lightly the cockpit or stem to the steerer tube.

**i** INFORMATION: Grease is not necessary at this stage.

**⚠ WARNING:** At this stage, the ICS wedge is neither required nor recommended. Do not tighten the stem's steerer-clamping bolts. Tightening these bolts without the ICS wedge installed can compromise the integrity of the steerer tube and may lead to failure and serious injury.



- Control the handlebar stack and reach to make sure the setup is matching the original bike fit coordinates.
- Using a silver or white marker pen, make a mark on the steerer tube at the top of the stem.

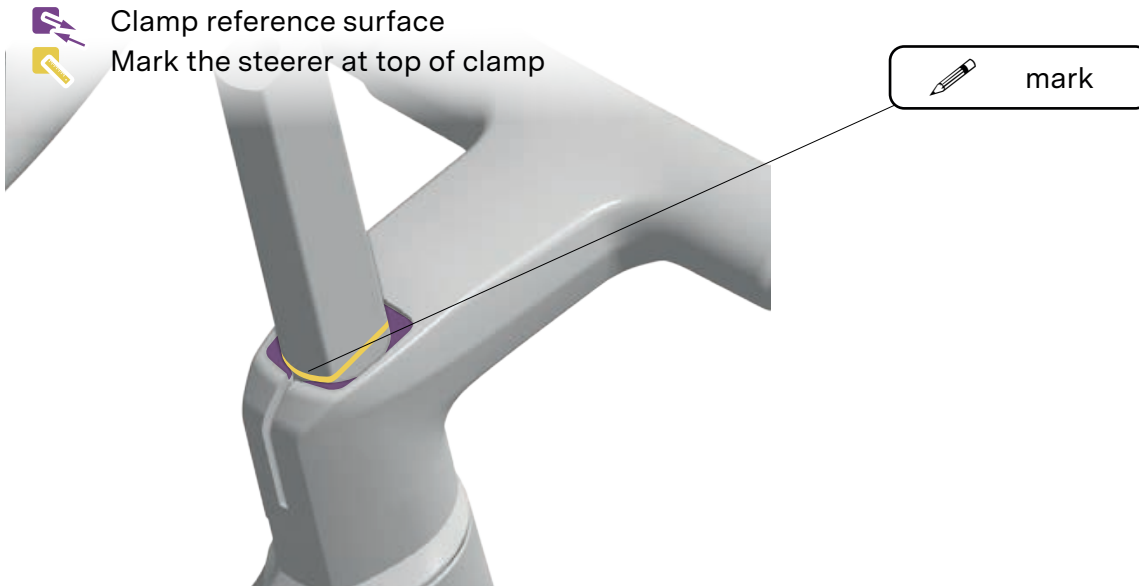

### ICS Carbon Aero Cockpit Gen 1 -and- ICS Carbon Evo Cockpit



### ICS Carbon Aero Cockpit Gen 2





## ICS2 Stem

-  Clamp reference surface
-  Mark the steerer at top of clamp



## RSM01 with ICS Core

-  Clamp reference surface
-  Mark the steerer at top of clamp

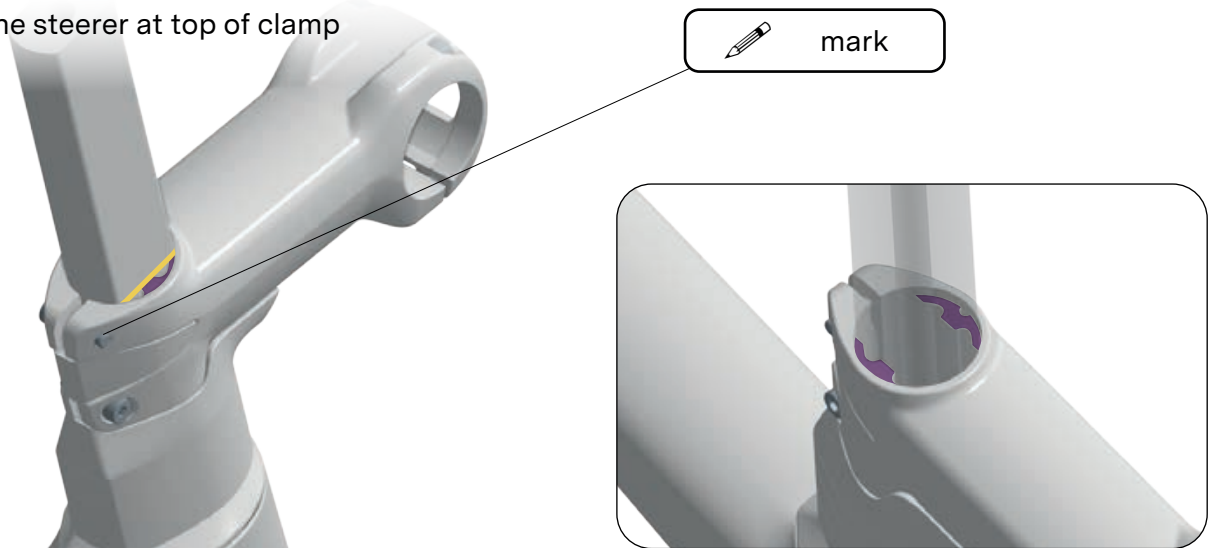

9. Uninstall the fork and headset from the frame.



## Steerer Tube Length and Cutting

**⚠ WARNING:** While it is possible to ride with a steerer tube extending above the stem, we strongly recommend cutting it to the appropriate length. This minimizes the risk of injury while riding or in the event of a fall.

10. From the previously marked line, measure and mark a new cutting line 2 to 3mm lower.
11. Use a carbon saw blade to cut the steerer tube.
12. After cutting, lightly sand the sharp edges of the pivot using a fine abrasive.



Report cutting length

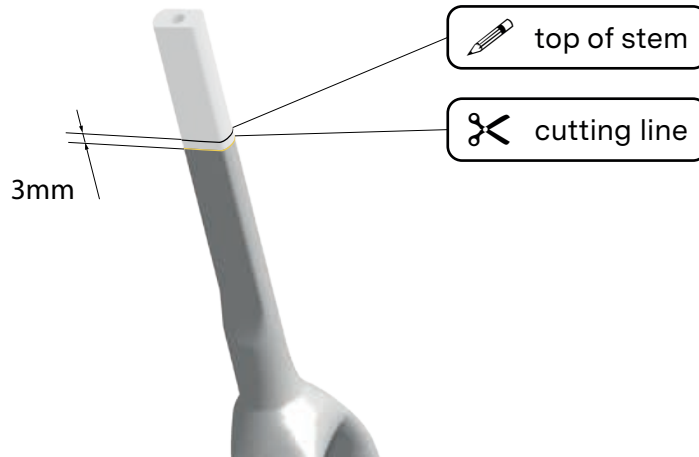

**⚠ WARNING:** The steerer tube must be cut to ensure proper headset compression and preload. After assembly, there should be approximately 1 mm of clearance between the top of the steerer tube and the underside of the top cap when the headset is fully compressed.

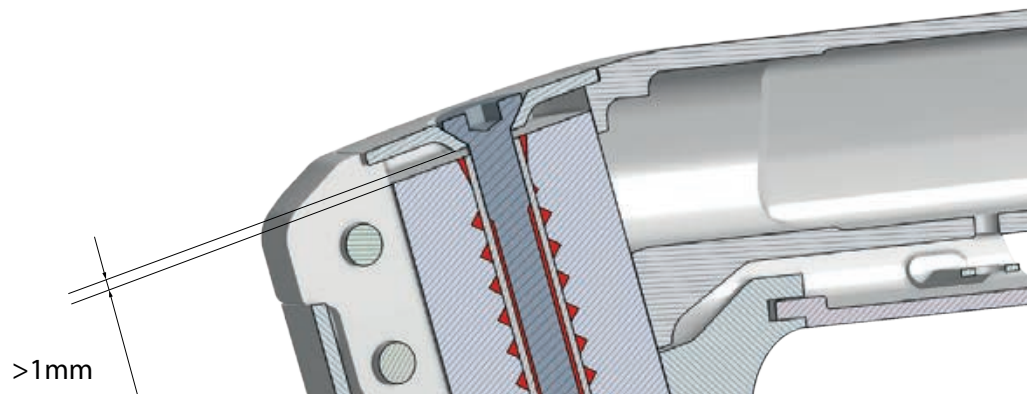

**i INFORMATION:** Applying tape underneath the cutting line will help guide the saw blade and reduce the risk of carbon delamination.

**i INFORMATION:** Use a saw guide and an appropriate carbon-specific saw blade, such as the Park Tool CSB-1.

## Expander Installation

- Grease the self-cutting expander bolt to facilitate installation.
- Push the expander into the flat steerer foam and turn it clockwise while applying downward pressure.
- Tighten until the expander bolt head is flush with the top of the steerer.

 Grease

 Screw in the self-cutting expander until it's flush

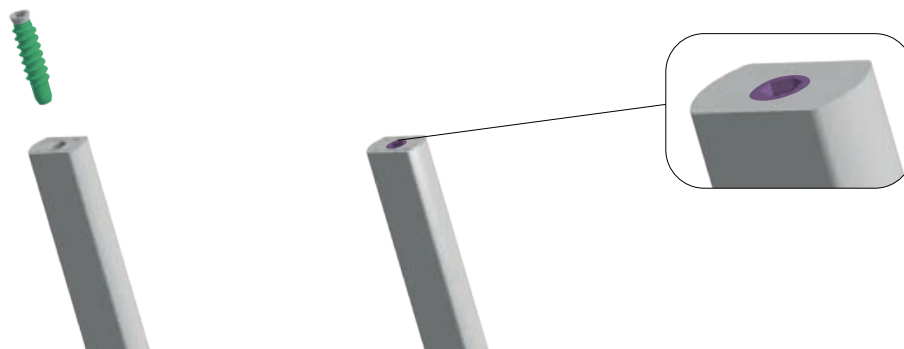



# Brake Calipers Assembly

## Rear Brake

The rear brake must be installed either:

- Directly on the frame brake mount for 160mm rotor compatibility
- Using a 20mm bracket for 180mm rotor compatibility.

1. Select the rear brake adapter and bolts. Refer to brake caliper's manufacturer to determine:
  - The correct adapter plate based on your rotor size.
  - The correct bolt length for frame mount of 25mm thickness.
  - The appropriate torque value.

**⚠ WARNING:** Always use the rear brake bracket specified by the brake caliper manufacturer.

160mm rotor = no adapter



 Use adapter for 180mm rotor



2. Push the rear brake hose from the back to the front inserting it in the left chainstay opening.
3. Guide the hose through the downtube and let the hose exit at the front of the bike.
4. To avoid noise and rattling, install a foam tube over the brake hose and push it so it fits within the middle of the downtube.



Route through chainstay and downtube

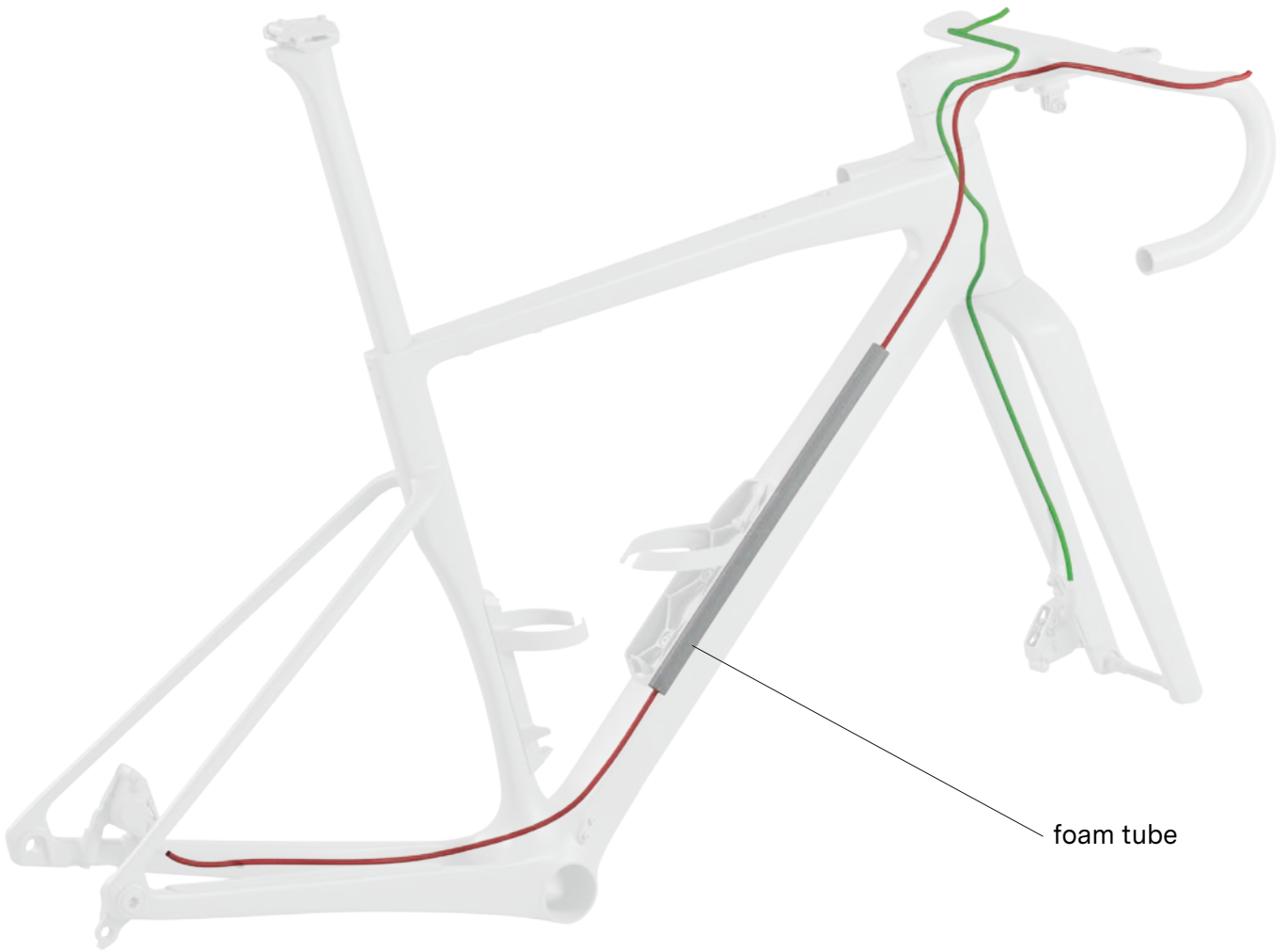



5. Bolt on the rear caliper on the flat mount brake mount using appropriate bolts and follow brake manufacturer's recommendation for installation (threadlocker and torque)



## Front brake

The front brake must be installed directly onto the specific BMC “TM-R” front bracket adapter. The Kaius is designed exclusively for a 160mm front rotor.

**⚠ WARNING:** Several front brake adapter plate designs exist. Make sure to use the plate supplied with the Teammachine R, identified by the ‘ONLY TM-R’ marking.

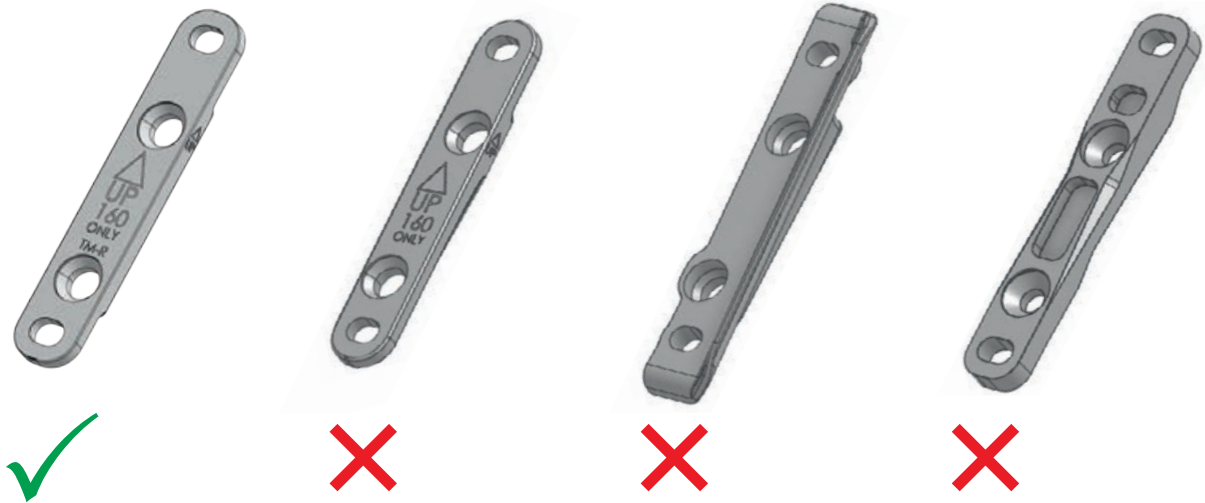

1. Install the front caliper adapter plate onto the front caliper.
2. Ensure the brake mount is in the correct position. The “UP” mark must face upward and outward, as shown in the illustration below.

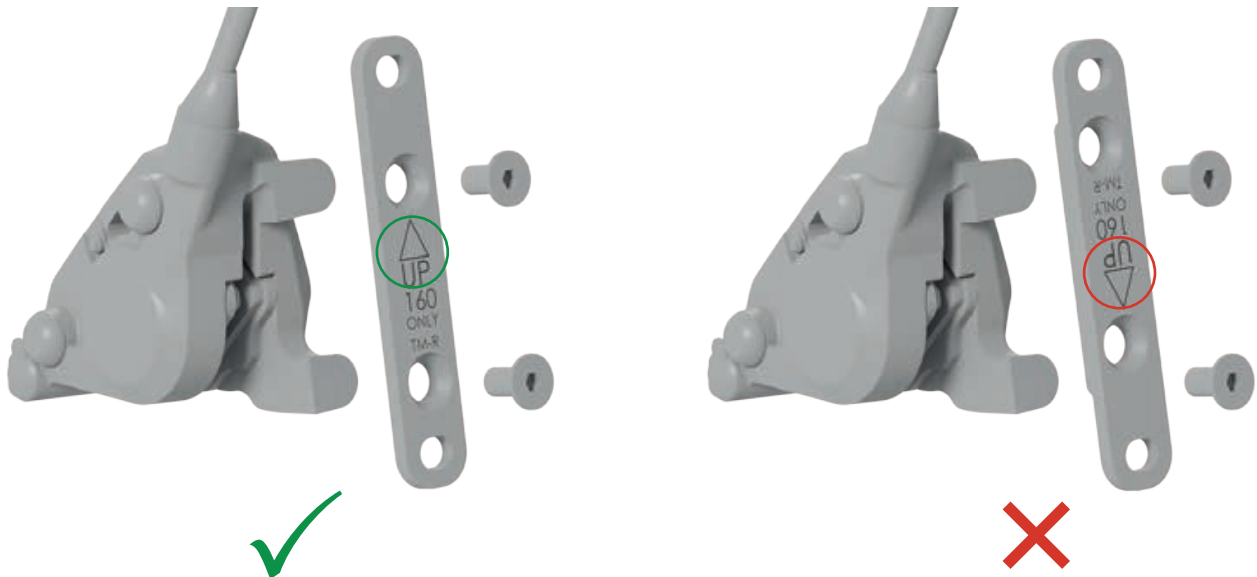

3. Torque the countersunk bolts according to the brake caliper manufacturer’s recommendations.
4. Route the front brake hose through the fork.
5. Install the front brake adapter to the fork mount using the two M5x14 bolts.

**⚠ WARNING:** remove old threadlocker and apply a new coat of LOCTITE® 243 Blue threadlocker.



 Thread locker

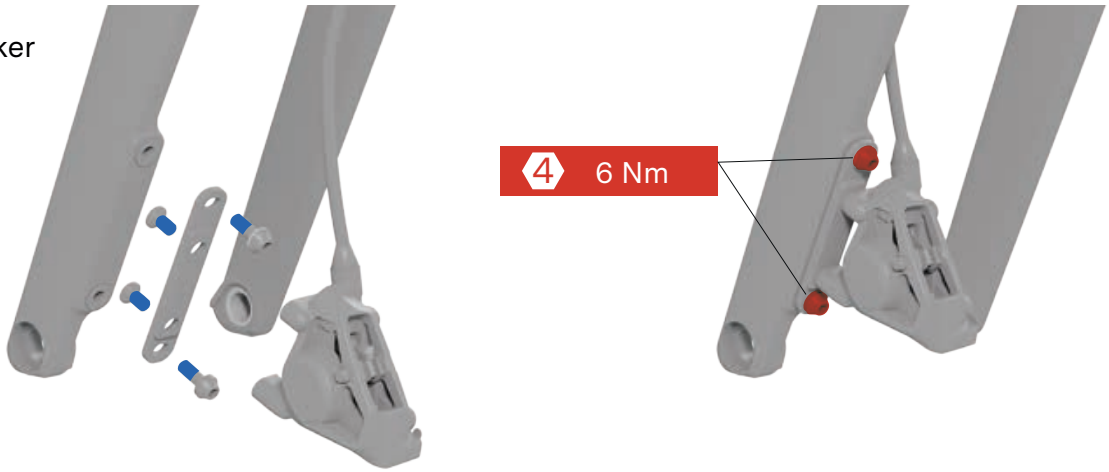

6. Tighten to 6 Nm using a hex 4mm wrench.

7. Route the front brake hose alongside the flat steerer.  
Follow the table instruction to place the hose on the appropriate side of the steerer tube.

	<b>Standard setup</b> front brake = left hand	<b>UK setup</b> front brake = right hand
<b>ICS Carbon Aero Cockpit Gen 1 -and- ICS Carbon Evo Cockpit</b>	right drive side	left non drive side
<b>ICS Carbon Aero Cockpit Gen 2 -and- ICS Stems</b>	left non drive side	right drive side

8. Hold the brake hose on the flat steerer by wrapping with electrical tape.

**⚠ WARNING:** Do not use tape on fork with 50mm rake specified on sizes 56, 58, 61.

routing on the  
left / non-drive side

routing on the  
right / drive side

50mm rake Fork  
Sizes 47, 51, 54

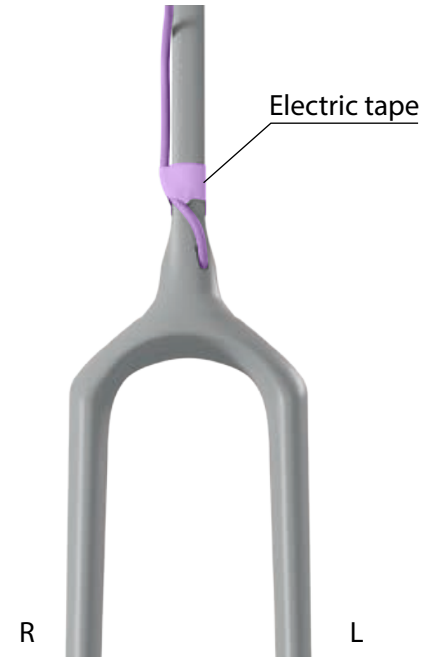
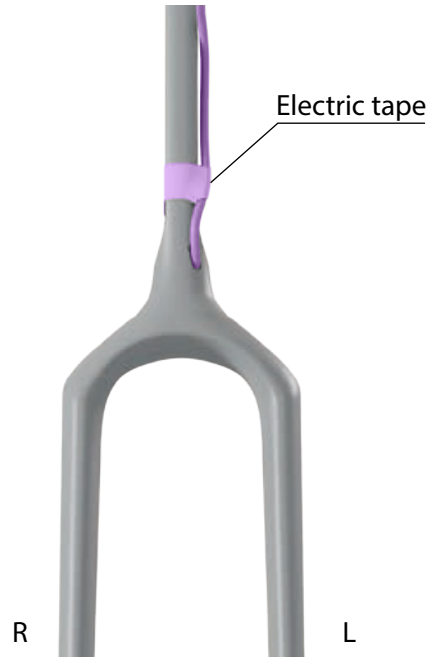

45mm rake Fork  
Sizes 56, 58, 61

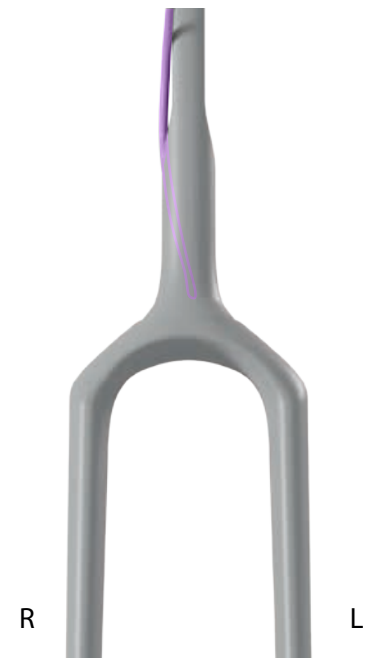



# Headset, Top Cone and Spacers Assembly

## Headset Assembly

The Kaius is designed to fit and specified with either BMC by FSA, HS-B-13, HS-B-27 bearings set.

**⚠ WARNING:** Always use the compression ring that matches the headset type.

Specifications of these bearings are:

HS-B-13-P	Reference	Dimensions	
			Nylon (green color) Compression ring H2318
<b>Upper bearing</b>	FSA MR155	30.5 x 41.8 x 7.5 ; 45x45°	Upper bearing MR155 30.5 x 41.8 x 7.5 ; 45x45°
<b>Lower bearing</b>	FSA MR019	40.0 x 51.8 x 7.5 ; 45x36°	Lower bearing MR019 40.0 x 51.8 x 7.5 ; 45x36°

HS-B-27-P Stainless	Reference	Dimensions	
			Nylon (green color) Compression ring H2318
<b>Upper bearing</b>	FSA MR042S	30.5 x 41.8 x 8.0 ; 45x45°	Upper bearing MR042S 30.5 x 41.8 x 8.0 ; 45x45°
<b>Lower bearing</b>	FSA MR110S	40.0 x 51.8 x 8.0 ; 45x36°	Lower bearing MR110S 40.0 x 51.8 x 8.0 ; 45x36°

Headset TM R Mpc	Reference	Dimensions	
			Nylon (black color) Compression ring
<b>Upper bearing</b>	Ceramic Speed 111820	30.5 x 41.8 x 8.0 ; 45/45°	Upper bearing 111820 30.5 x 41.8 x 8.0 ; 45/45°
<b>Lower bearing</b>	Ceramic Speed 111954	40.0 x 51.8 x 8.0 ; 36/45°	Lower bearing 111954 40.0 x 51.8 x 8.0 36/45°

**i INFORMATION:** Upgrade of bearings headsets is possible with:  
 30007215 Headset TM R Mpc Ceramic Speed headset bearings  
 30007614 HS B 27 Stainless headset bearings

 Grease

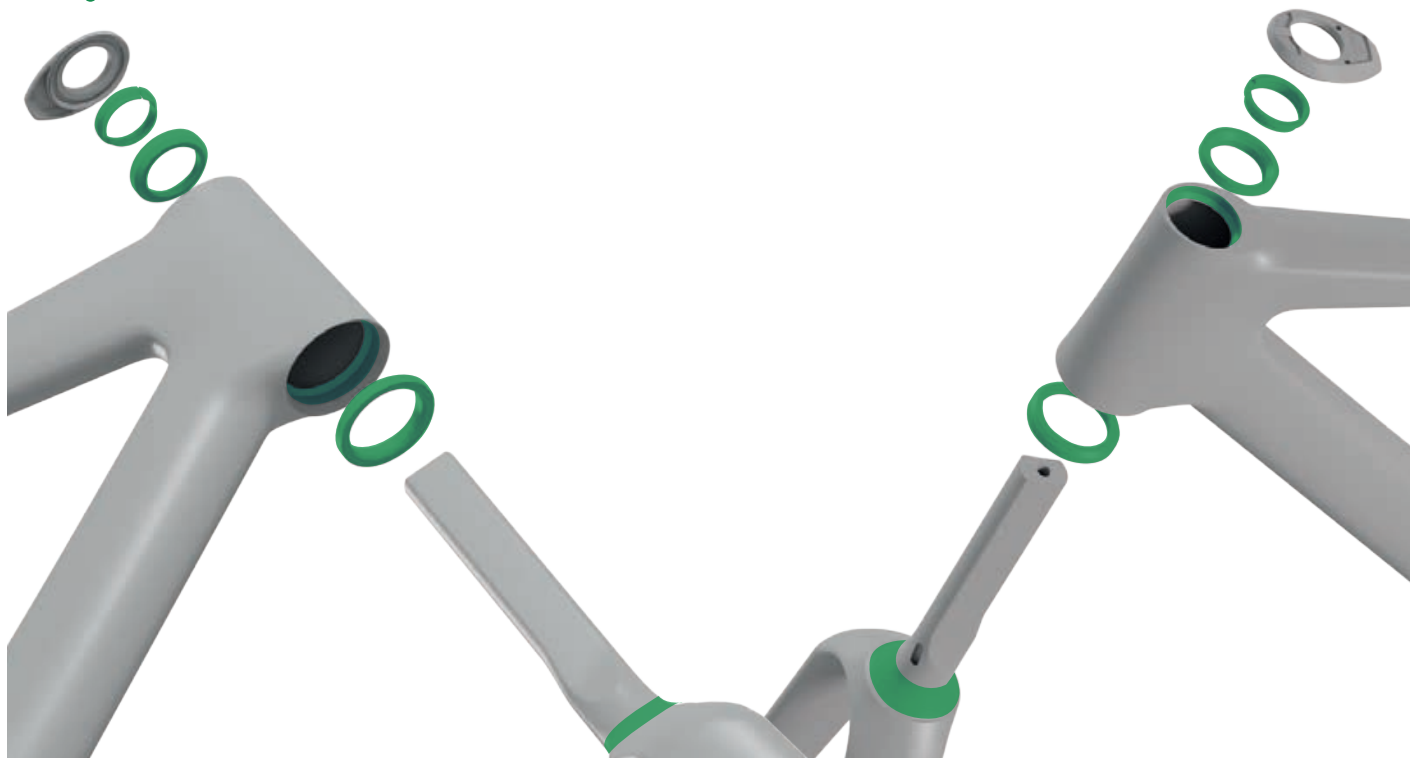

1. Install the lower bearing on the fork crown, applying grease to the frame bearing race, fork crown contact surface, and bearing surfaces.
2. Route the front brake hose through the head tube, then insert the fork steerer tube through the head tube and headset bearings.
3. As the front and rear brake hoses exit from the top of the head tube, install the upper bearing in the frame head tube, applying grease to the frame bearing race and bearing surfaces.
4. Grease the headset compression ring and slide it onto the steerer tube, ensuring its slot is oriented to either the right or left side.

 Compression ring orientation



 **WARNING:** Do not orient the compression ring slot straight toward the front or back. Doing so will negatively affect the compression of the headset. Turn it 45° or 90° so it does not touch the steerer tube directly.

 **WARNING:** Do not apply friction paste to the steerer tube or the bearings.



## Cockpit or Stem Installation

- Route front and rear brake hoses through the stem or cockpit. Follow the table instruction to place each hose on the correct side of the stem or cockpit guides.

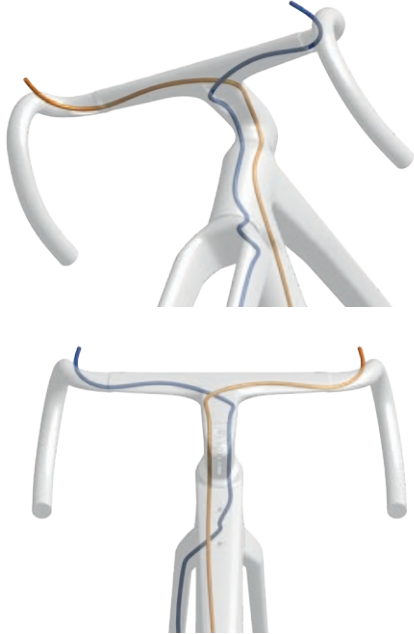
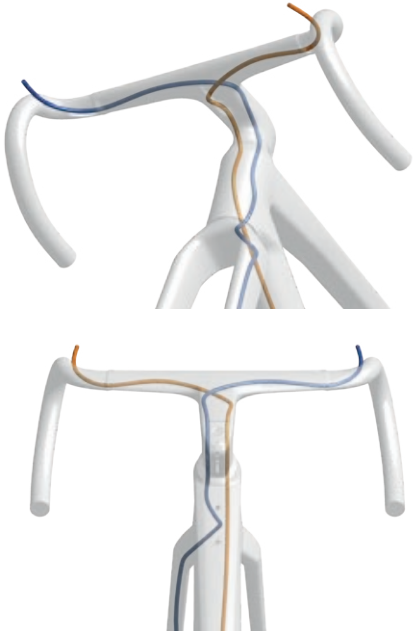
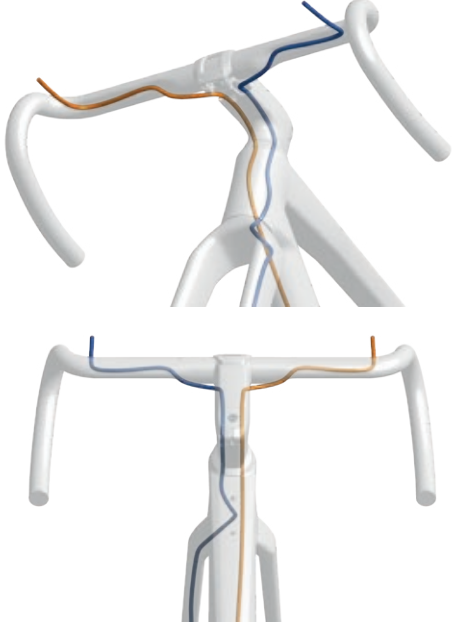
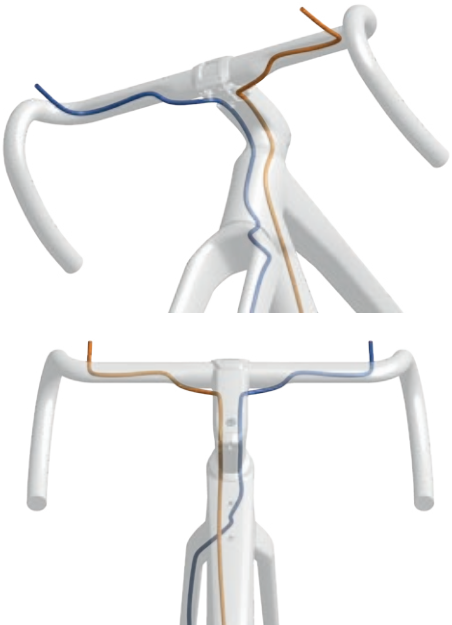
	Standard setup front brake = left hand	UK setup front brake = right hand
ICS Carbon Aero Cockpit Gen 1 -and- ICS Carbon Evo Cockpit		
ICS Carbon Aero Cockpit Gen 2 -and- ICS Stems		

- Compile the different elements of the stem/handlebar or cockpit as determined in “Fork, Headset and Cockpit Preparation” on page 31.

**⚠ WARNING:** Do not tighten the stem steerer clamping bolts without the ICS flat steerer wedges. Tightening the stem steerer clamping bolts can compromise the integrity of the steerer tube – leading to failure and serious injury.

# Headset Compression and Clamping the Stem

1. Once the frame and fork are assembled with the headset, spacers, stem or cockpit, and top cap, torque the preload bolt to 4 Nm.
2. Refine the handlebar-wheel alignment using the slight rotational freedom provided by the ICS system.
3. Torque the stem/cockpit bolts as indicated on the stem/cockpit or according to the torque values provided below.

**⚠ WARNING:** Correct headset preload is crucial for a safe, play-free steering system.

## ICS Carbon Aero Cockpit Gen 1 -and- ICS Carbon Evo Cockpit

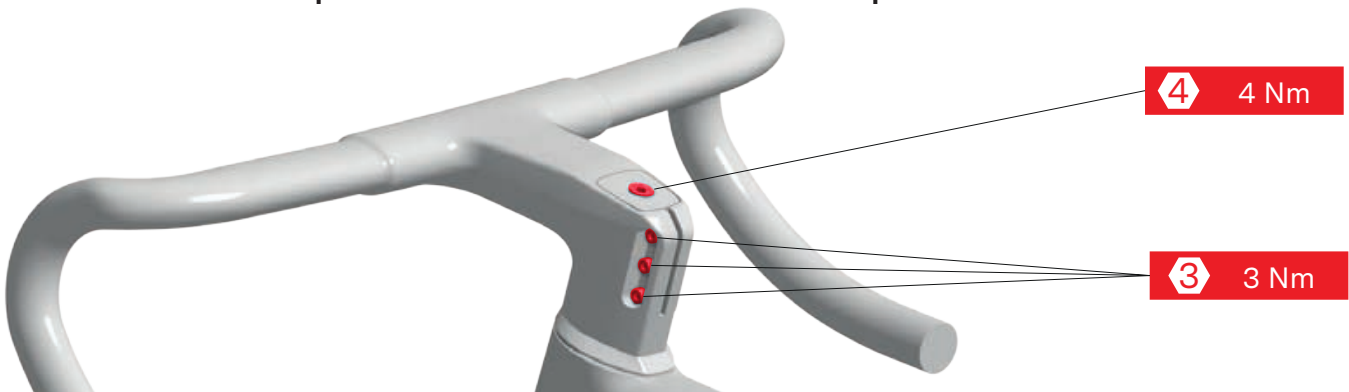

## ICS Carbon Aero Cockpit Gen 2

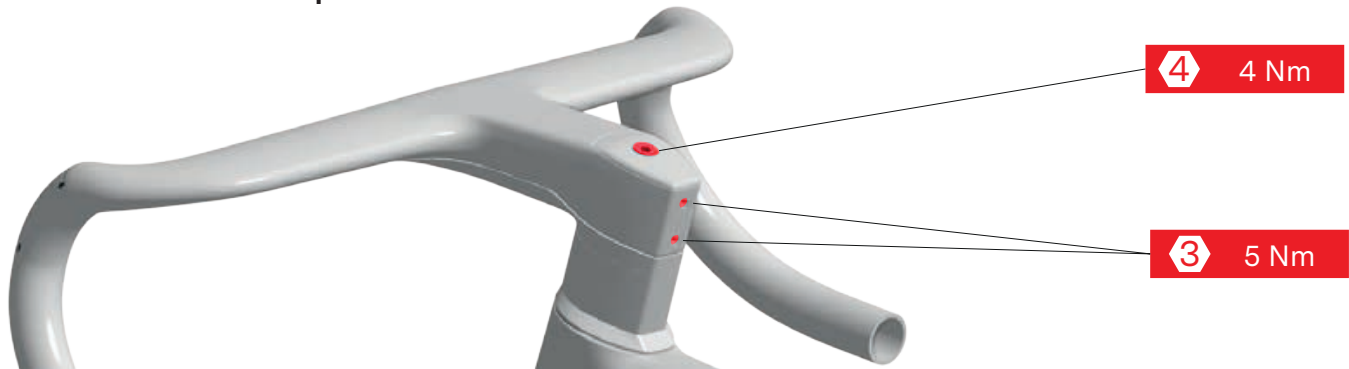

## ICS Stem

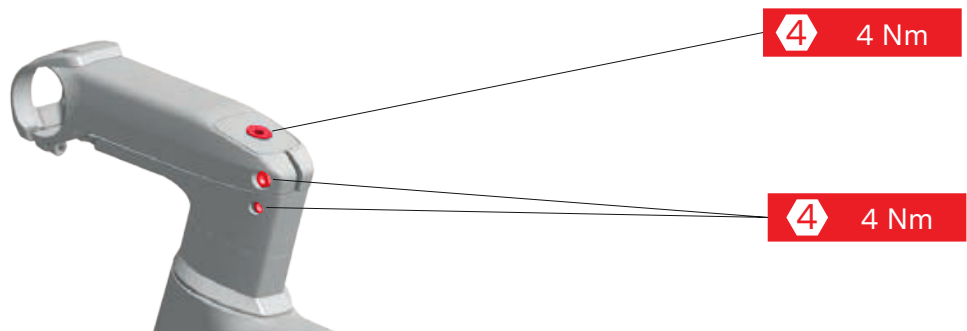

## RSM01 with ICS Core

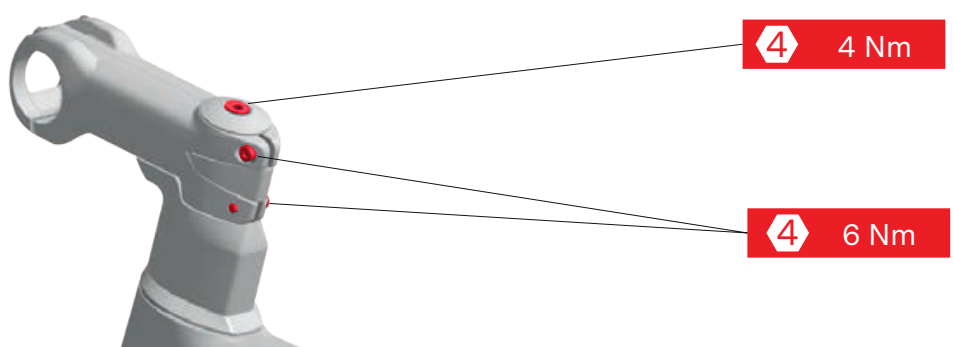



## Bottom Bracket and Crankset Assembly

1. Now that all the cables and brake hoses are installed, you can install the bottom bracket and the crankset.

**⚠ WARNING:** Always install the brake hose first.

**ℹ INFORMATION:** The Kaius uses a T47 85.5mm Road Wide (internal bearings) bottom bracket.

**⚠ WARNING:** Please follow the bottom bracket and crankset instructions for installation. Use tightening tools cautiously to prevent damage to the frame paint.

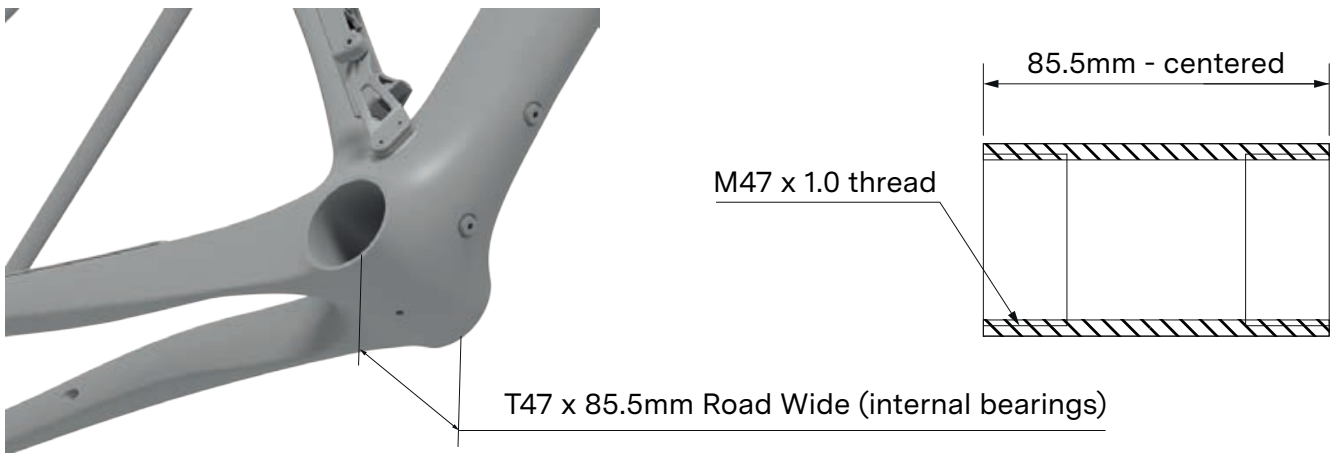

## Chain-guide Installation

**ⓘ INFORMATION:** Our Kaius frames are designed to accommodate round chainrings of maximum 50 teeth and minimum 32 teeth without chain-guide and 38 teeth with chain-guide.

**ⓘ INFORMATION:** Our Kaius frames and its chain-guide are designed for road chainline of minimum 47.5mm and maximum 49.7mm.

**⚠ WARNING:** Chainrings and chainlines outside of the range listed above can not be guaranteed compatible with our frame design. An assembly check is necessary to confirm a 4mm minimum clearance between the chainring, chain and frame.

1. Select the chain-guide option depending on your drivetrain and your preferences:

38t > 42t = Short chain-guide plate

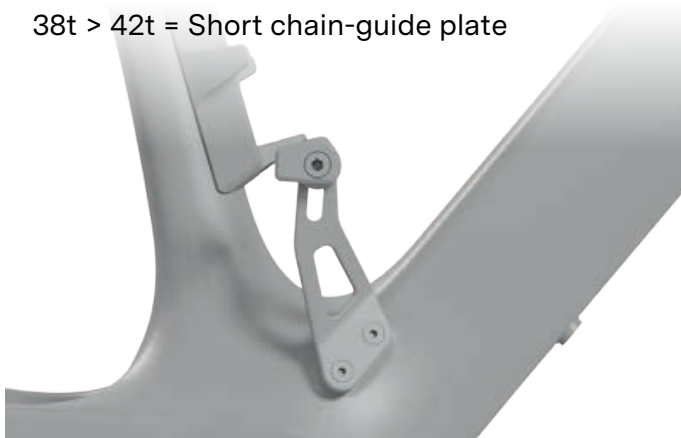

44t > 50t = Long chain-guide plate

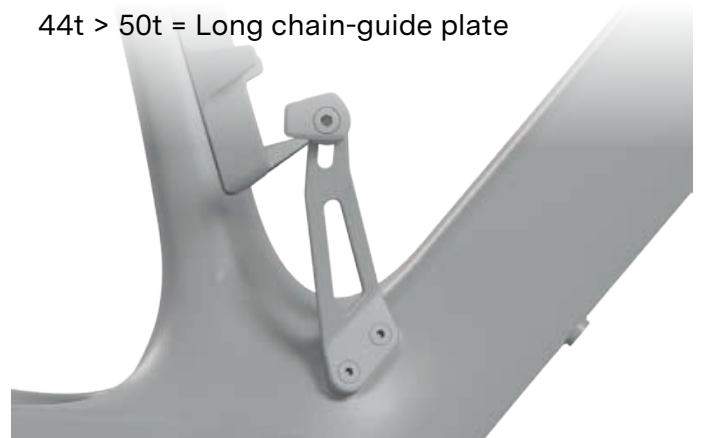

	SRAM 47.5mm chainline			SHIMANO 49.7mm chainline		
	32t to 36t	38t to 42t	44t to 50t	32t to 36t	38t to 42t	44t to 50t
<b>No chain-guide</b>	✓ compatible	✓ compatible	✓ compatible	✓ compatible	✓ compatible	✓ compatible
<b>With chain-guide</b>	✗	Short plate no shim	Long plate no shim	✗	Short plate + shim	Long plate + shim



2. Grease the two M3x16mm countersunk bolts and tighten all selected parts using a hex 2mm.
3. Tighten to 1 Nm.

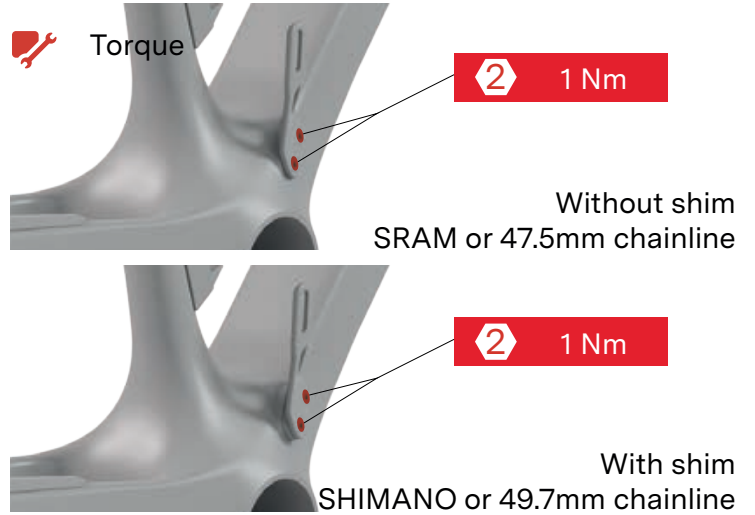

4. Assemble the guide head without tightening to torque yet.

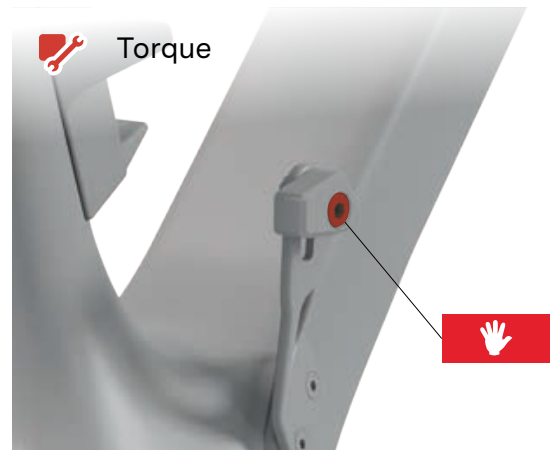
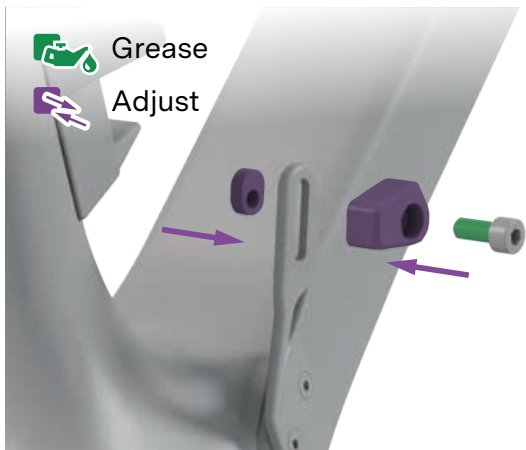

5. Assemble your crankset and chainring.
6. Adjust height and angulation of the chain-guide head to keep a minimum of 1mm between the chain and the bottom of the chain-guide head.
7. Tighten to 2 Nm using a hex 3mm.

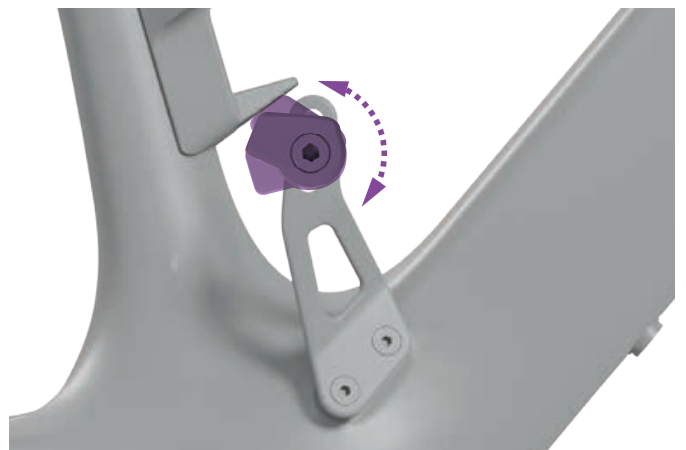
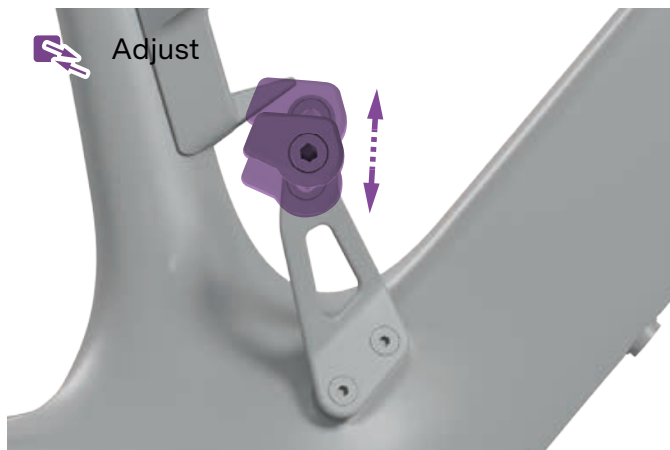

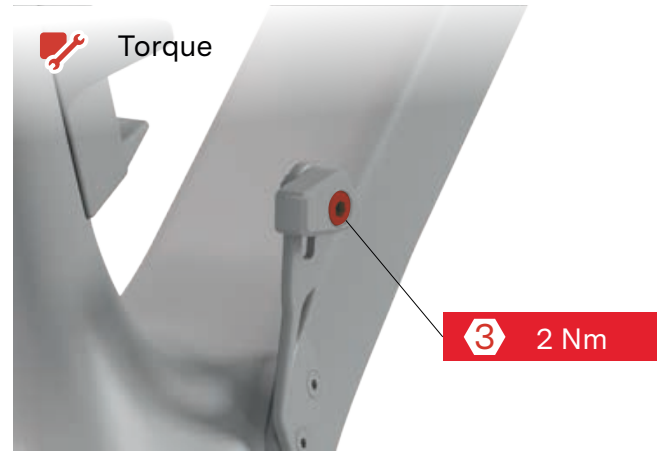
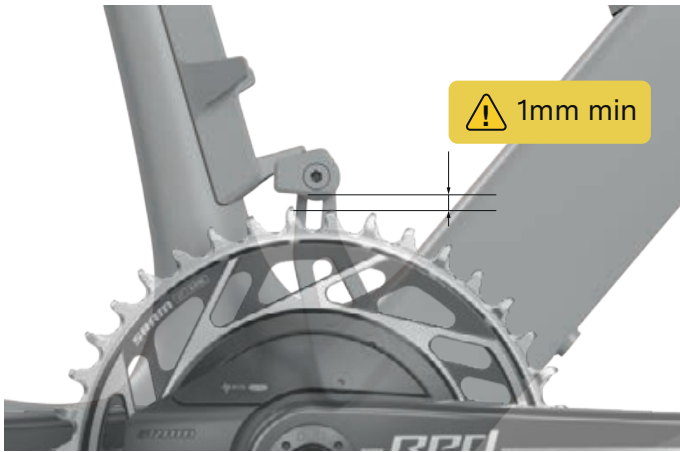

**i** INFORMATION: The chain-guide nut can be replaced by a standard M4 nut if damaged .



## Bottle Cages

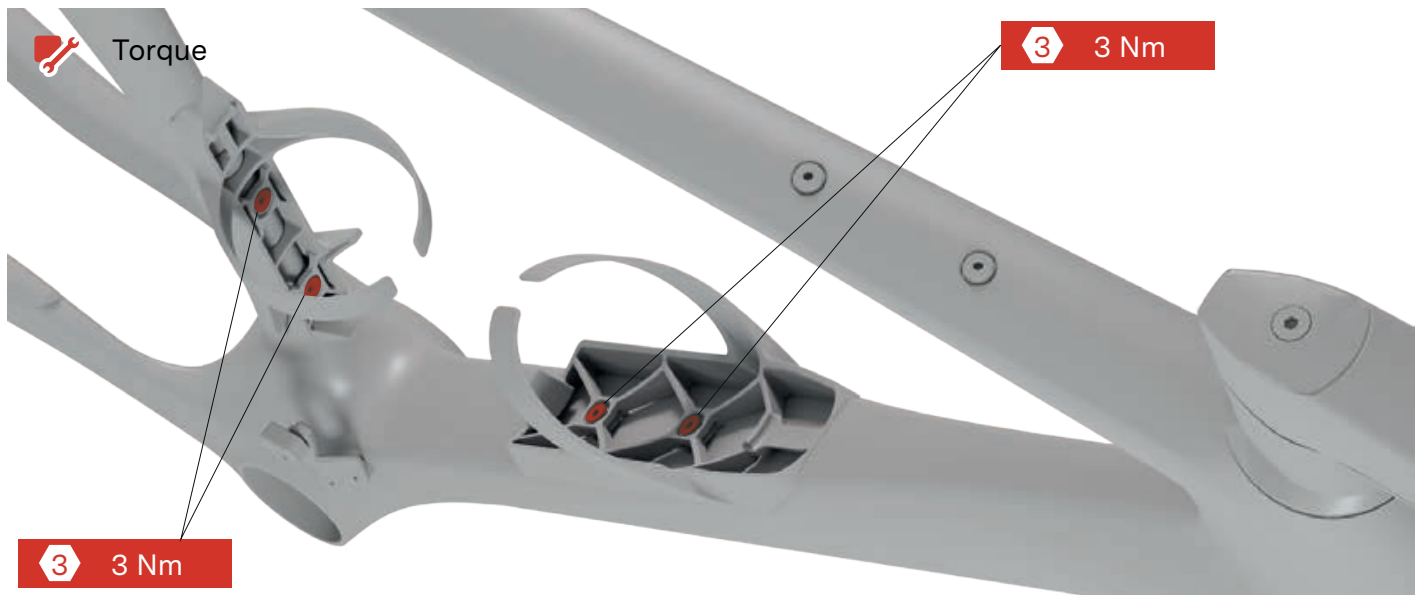

**ⓘ INFORMATION:** Kaius is designed for BMC Aerocore bottle cages type N°3 (WBC AS No. 3). Kaius is however compatible with traditional bottle cages.

1. Install the BMC bottle cages or the bottle cage of your choice.
2. Tighten the 2x M5x12 bolts to 3 Nm using a hex 3mm wrench.

## Cargo Mounts and Top Tube Plate

The Kaius features two bottle cages and three dedicated cargo-mounting points:

**⚠ WARNING:** Maximum allowed load per cargo mount is limited to 500g.  
Ensure items are tightly fixed and do not shift while riding

 Torque

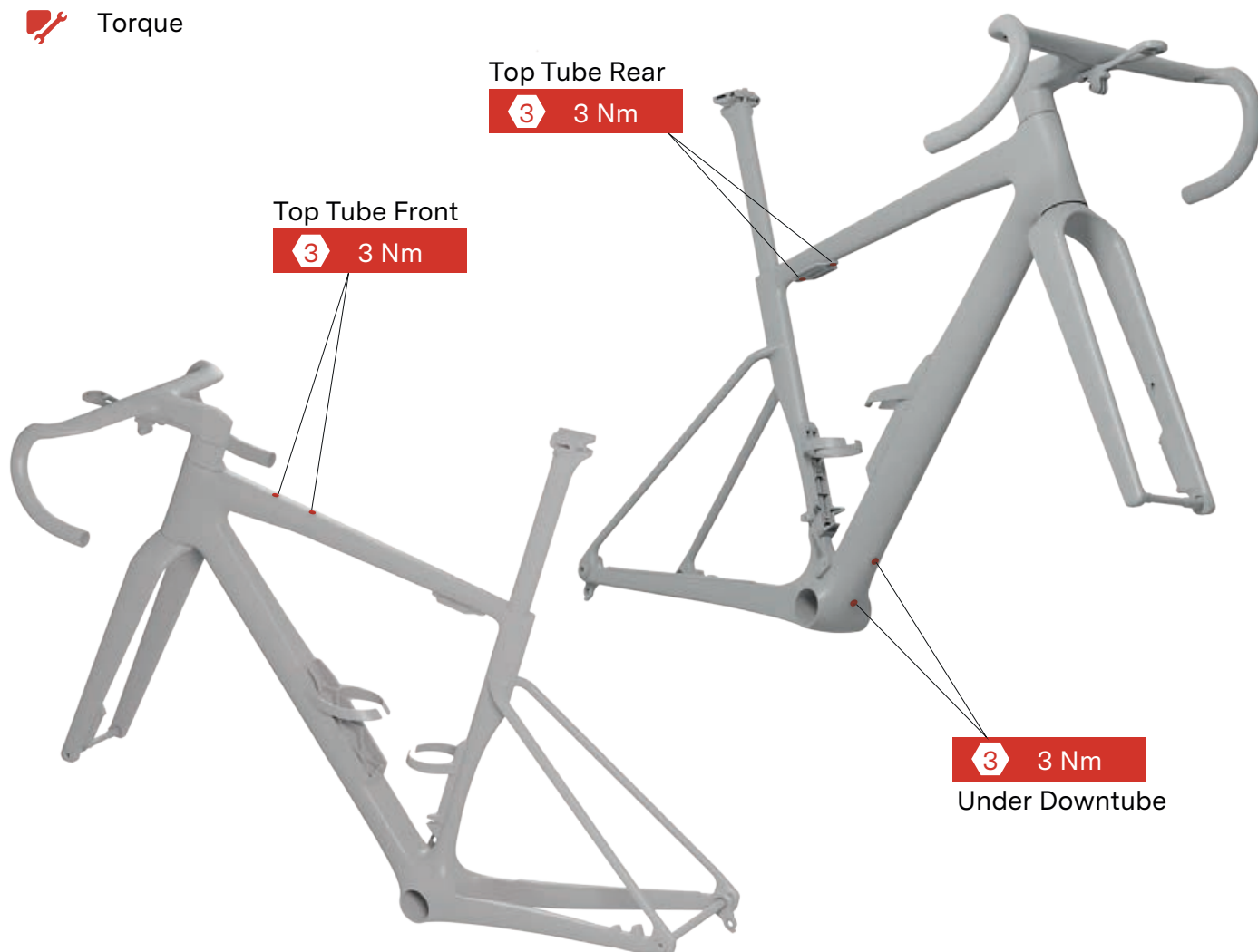

1. Install the BMC bottle cages or the bottle cage of your choice.
2. Tighten the 2x M5x12 bolts to 3 Nm using a hex 3mm wrench.



## Top Tube – Front Position

Located on the upper side of the top tube, near the head tube.

Suitable for: small pouches, nutrition boxes, fuel bags, electronic accessory mounts.

## Top Tube – Rear Position (with Cargo Plate)

Includes a cargo plate.

Designed to hold: spare inner tubes, CO<sup>2</sup> cartridges, small tools, nutrition.

The cargo plate can be used with 3M Velcro straps or an elastic strap to secure items safely.

1. Place the accessory centered on the plate.
2. Wrap the Velcro or elastic strap through the designated slots.
3. Ensure tension is firm but does not deform the item.
4. Check stability before riding.

 Adjust



## Under Downtube – Bottom Bracket Area

Mounting bosses located under the downtube near the bottom bracket.

Best for: tool capsules, spare tubes, compact bottles, mud-proof accessory holders.

 **WARNING:** Avoid placing fragile items here due to proximity to debris impact .

# Wheels and Axles

**⚠ WARNING:** Your bike is delivered pre-assembled with inner tubes for transportation and display. Always setup the wheels following the recommendations and instructions of the wheel and the tire manufacturers:

Some wheels must only be assembled tubeless.

Some wheels must only be installed with specific tires for a tubeless setup (hookless rims).

Even if the wheels are tubeless, some tires assembled on some bike models may not be tubeless compatible.

Please read carefully the tires and the wheels instructions.

**⚠ WARNING:** Make sure tubeless compatibility is guaranteed between your wheels and your tires:

Minimum and maximum tire size measured at riding pressure.

Minimum and maximum tire pressure.

Tire bead design (hooked or hookless).

Rim design (hooked or hookless).

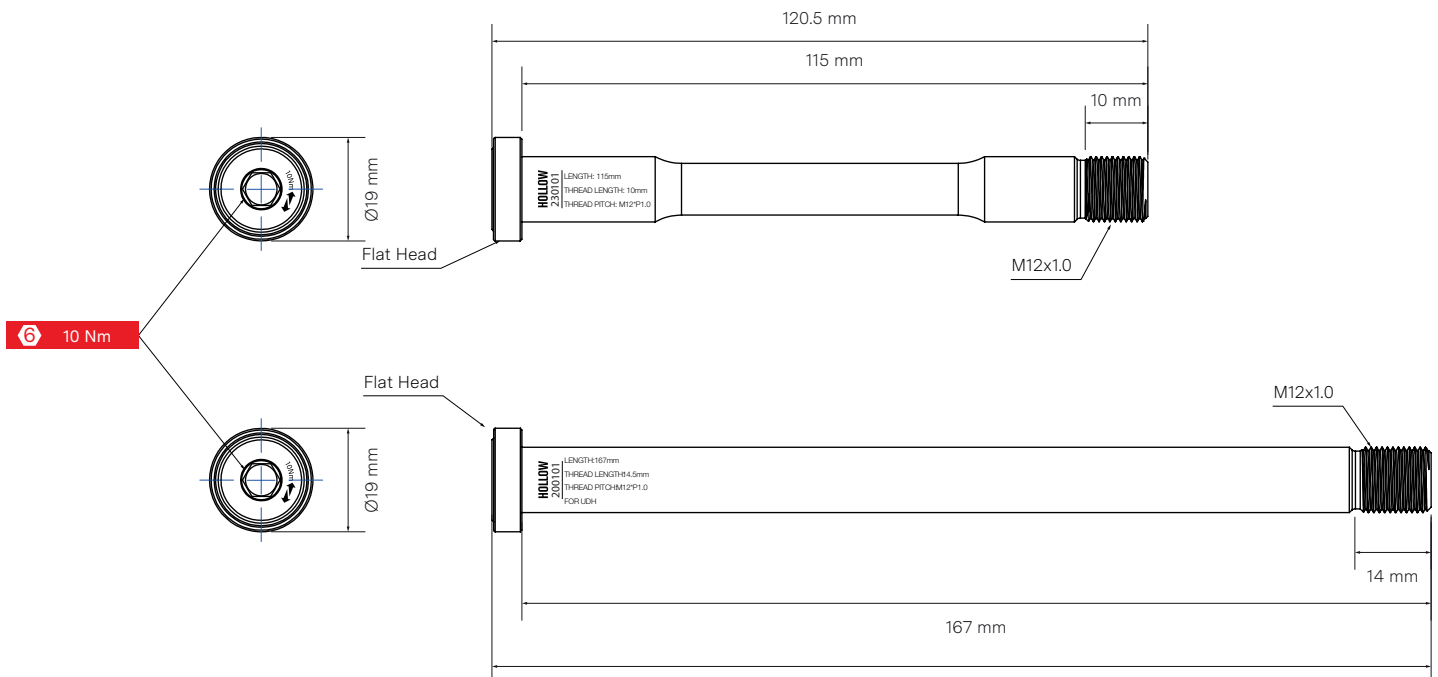



1. Grease the thread and the head of the thru-axes.
2. Thru-axes must be torqued to 10 Nm using a hex 6mm.

 Grease

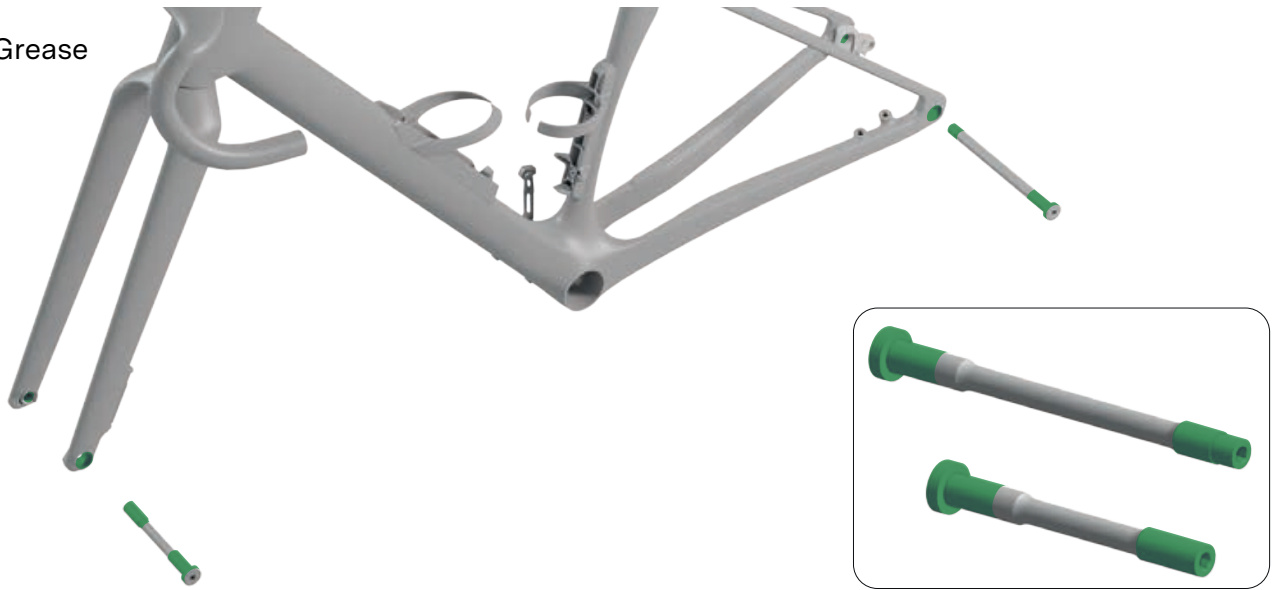

 Torque

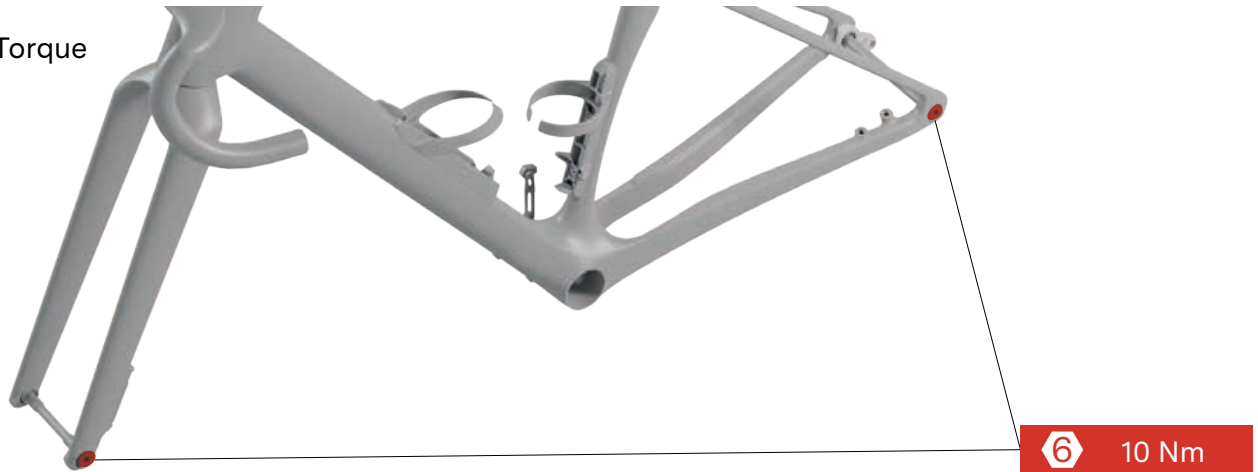

## Fenders

Kaius is only compatible with quick mount clip-on third party fenders.

Engineered to be the lightest, the Kaius does not feature threads and brackets to install classic fenders using stays bolted on the frame and fork.

Examples of quick mount clip-on fenders

- SKS Raceblade Pro
- TOPEAK Tetrafender R1 / R2
- TOPEAK Defender RC1 / RC11

**⚠ WARNING:** You must carefully install your fenders so they don't damage your frame or its components. Road vibrations could cause the fenders to vibrate and rattle causing paint damage and frame structural damage or components damage. Damage may result in component failure and result in loss of control and falling.

**⚠ WARNING:** Avoid fixing systems other than elastic bands or fabric straps and protect the frame by applying protective tape. Clamping with clamps or bolt-on mechanism may damage the frame structure and paint.

**⚠ WARNING:** Lots of fender options are available on the market. Even if their design is optimized for road bikes, you may have to modify their shape.

Always follow the fender manufacturer's recommendation for installation.

**⚠ WARNING:** Tire clearance is affected by the installation of fenders. Always respect a clearance of 6mm all around the tire to guaranty your safety.

Depending on your fender choice and installation, you may have to change your tire size to get the appropriate tire-to-fender clearance.

You can attach the quick mount clip on fenders on limited areas of the fork blades, seat stays, seat tube and seat post.

 Straps or elastic application zones





# Service Instructions

The BMC Kaius is a high-tech, performance oriented product. We ask you to take care of your bike if you want it to deliver its maximum performance over the years.

If you notice parts that are worn out or damaged, do not hesitate to replace the part and or contact your BMC dealer.

## Washing Your Bike

You should never use a high pressure washing device to clean your Kaius.

Even with a lot of attention to detail, we cannot build a functional bike resistant to high pressure water.

We recommend using a brush and soft bike soap, and rinse with water at low pressure.

Avoid degreaser and brake cleaners directly on the frame, fork and handlebar area. Composite carbon and painted components could be permanently damaged and made fragile.

## After Washing

If there is water trapped in your frame, it should drain automatically from below the bottom bracket.

If the steering does not rotate freely, check the installation of the headset and stem. If the issue is not solved, it may be that your headset bearings need to be replaced.

If your seatpost makes an unusual noise after washing or riding in wet weather, you need to take the seatpost apart, clean the frame seat tube and the seatpost, and reapply carbon friction paste between frame and seatpost.

# Trouble Shooting

## Noise from the saddle or the seatpost:

- Apply friction paste between the seatpost and the frame seat tube.
- Apply grease on each element of the saddle clamp (bolt, washer, clamps).

## Noise from the drivetrain:

- Check rear derailleur assembly and rear dropout hanger assembly. Refresh the threadlocker compound on the dropout hanger bolts if necessary and tighten to torque.
- Check rear thru-axle: clean with a degreaser, reapply grease on thru-axle as indicated in this manual and reassemble tightening to the correct torque.
- Check bottom bracket and crankset following instructions from their manufacturer(s).

## Seatpost slipping down:

- Apply friction paste between the seatpost and the frame seat tube
- Disassemble, clean and degrease the seat clamp and grease bolts thread before reassembly.
- Check the torque at the seatpost clamp.

## Play in the headset:

- Remove the top cap and inspect the steerer-tube top and compression screw.
- Loosen the stem, and tighten lightly the headset compression bolt to 4 Nm.
- Tighten the stem back to the manufacturer's recommended torque.
- Verify that the fork steerer tube is cut to the correct length, ensuring a 1 mm gap between the top cap and the steerer tube.

## Friction in the headset:

- Make sure nothing is stuck between head tube and fork or between the headset top cone the head tube.
- Check the headset bearings and replace them if necessary.

## Play in the stem/handlebar area:

- Do not ride with play in the cockpit or stem/handlebar assembly.
- Check the torque settings of every single bolt.
- Apply grease, thread lock and friction paste as indicated in this manual.
- Check that none of the stem bolts are damaged.



# Notes

A series of horizontal dotted lines spanning the width of the page, intended for taking notes.

**BMC**



BMC Switzerland AG  
+41 32 654 14 54

Sportstrasse 49 |  
info@bmc-switzerland.com

CH-2540 Grenchen | Switzerland  
www.bmc-switzerland.com